



EPQ Policies Considering the Holding Cost of Raw Materials with Two-Level Trade Credit under Alternate Due Date of Payment and Limited Storage Capacity

Ghi-Feng Yen¹, Shy-Der Lin², An-Kuo Lee¹

¹Department of Business Administration, Chung Yuan Christian University, Taiwan

²Department of Applied Mathematics, Chung Yuan Christian University, Taiwan

Email: gfyen@cycu.edu.tw, shyder@cycu.edu.tw, dreamair@icloud.com

How to cite this paper: Yen, G.-F., Lin, S.-D. and Lee, A.-K. (2018) EPQ Policies Considering the Holding Cost of Raw Materials with Two-Level Trade Credit under Alternate Due Date of Payment and Limited Storage Capacity. *Open Access Library Journal*, 5: e5041.

<https://doi.org/10.4236/oalib.1105041>

Received: November 8, 2018

Accepted: December 17, 2018

Published: December 20, 2018

Copyright © 2018 by authors and Open Access Library Inc.

This work is licensed under the Creative Commons Attribution International License (CC BY 4.0).

<http://creativecommons.org/licenses/by/4.0/>



Open Access

Abstract

The traditional Economic Production Quantity (EPQ) model focused on production process, used the ordering cost that includes relevant costs during the pre-production process. But, the ordering cost comprises the holding of raw materials that would be affected by other factors would increase the total relevant cost, it cannot simply use the ordering cost to cover all. Therefore, this paper presents a new inventory model by considering the holding of raw materials under conditions of two-level trade credit under alternate due date of payment and limited storage capacity. According to cost-minimization strategy it develops four theorems to characterize the optimal solutions. Finally, it executes the sensitivity analysis and investigates the effects of the parameters in the annual total relevant costs.

Subject Areas

Industrial Engineering

Keywords

EPQ, Raw Materials, Alternate Due Date of Payment, Trade Credit, Limited Storage Capacity

1. Introduction

[1] and [2] developed the Economic Order Quantity (EOQ) model and the Economic Production Quantity (EPQ) model for inventory management respectively. For convenience to mathematical analyses, the parameter ordering cost

includes relevant costs during pre-production process, one of them is the holding cost of raw materials. A supply chain consists of all stages involved not only suppliers and manufacturers, but also transporters, warehouses, retailers and customers [3]. When suppliers provide raw materials would affect many factors, such as climate change, shipping delays, and more, these would increase the total relevant cost. Therefore, the price fluctuation of raw materials becomes an important issue. [4] first modified the EPQ model to consider the holding cost of raw materials more close the practice, latter, the research of raw materials has been found in many papers [5] [6].

[7] established an EOQ model under the condition of permissible delay, [8] defined this situation as one-level trade credit. [9] and [10] generalized [7] to two-level of trade credit, provide a fixed trade credit period M between the supplier and the retailer, and a trade credit period N between the retailer and the customer. The different payment terms between [9] and [10] can be explained as follows:

1) [9]'s payment terms, if a customer buys one item from the retailer at time $t \in [0, T]$, then the customer will have a trade credit period $N - t$ and make the payment at time N . Therefore, a retailer allows a maximal trade credit period N for customers to settle the account [8] [11] [12] [13] [14] [15].

2) [10]'s payment terms, if a customer buys one item from the retailer at time $t \in [0, T]$, then the customer will have a trade credit period N and make the payment at time $N + t$. Therefore, a retailer allows a maximal trade credit period N for customers to settle the account [16]-[21].

The trade credit stimulates retailer purchase more quantities, and the increasing demand would cause more storage capacity to store goods. [22] developed an EOQ model for two-warehouse to solve if owned warehouse (OW) is insufficient, then store in a rented warehouse (RW) [12] [21]-[26].

[21] developed an EPQ model in [10]'s payment terms (and called it an alternate due date of payment), finite replenishment rate and limited storage capacity together, but they did not consider the affected by raw materials and annual purchasing cost. Therefore, this paper further develop a new EPQ model, including the holding cost of raw materials and annual purchasing cost to determine the optimal inventory policies. This paper structure modified three stages of [9] and [10] from "supplier, retailer, and customer" to "supplier, manufacturer, and customer (retailer)", and stand in a manufacturer's position to calculate the annual total relevant cost (include ordering cost, purchasing costs, holding costs, interest payable and interest earned). We use cost-minimization strategy to develop four theorems to characterize the optimal solution, and take the sensitivity analysis to find out the critical impact factors of the total relevant cost and draw the conclusions. For business managers, the model more close practice and can be very easy to use to calculate the optimal cycle and the annual total relevant costs. The accurate information to make these decisions as an important basis for an investment plan.

2. Notations and Assumptions

2.1. Notations

Q : the order size

P : production rate

D : demand rate

A : ordering cost

T : the cycle time

$$\rho = 1 - \frac{D}{P} > 0$$

L_{\max} : storage maximum

s : unit selling price per item

c : unit purchasing price per item

h_m : unit holding cost per item for raw materials in raw materials warehouse

h_o : unit holding cost per item for product in owned warehouse

h_r : unit holding cost per item for product in rented warehouse

I_p : interest rate payable per \$ unit time (year)

I_e : interest rate earned per \$ unit time (year)

t_s : time in years at which production stops

M : the manufacturer's trade credit offered by the supplier

N : the customer's trade credit period offered by the manufacturer

W : storage capacity of owned warehouse

tw_f : the point in time when the inventory level increases to W during the production period

tw_d : the point in time when the inventory level decreases to W during the production cease period $= T - \frac{W}{D}$

$tw_d - tw_f$: the time of rented warehouse

$$= \begin{cases} \frac{DT\rho - W}{P - D} + \frac{DT\rho - W}{D}, & \text{if } DT\rho > W \\ 0, & \text{if } DT\rho \leq W \end{cases}$$

$TRC(T)$: the total relevant cost per unit time of model when $T > 0$

T^* : the optimal solution of $TRC(T)$

2.2. Assumptions

- 1) Demand rate D is known and constant.
- 2) Production rate P is known and constant, $P > D$.
- 3) Shortages are not allowed.
- 4) A single item is considered.
- 5) Time period is infinite.
- 6) $h_r \geq h_o \geq h_m$, $M \geq N$ and $s \geq c$.
- 7) The storage capacity of raw materials warehouse is unlimited.
- 8) If the order quantity is larger than manufacturer's OW storage capacity, the manufacturer will rent and the RW storage capacity is unlimited. When the de-

mand occurs, if first is replenished from the RW which stores those exceeding items. It takes first in last out (FILO).

9) During the time the account is not settled, generated sales revenue is deposited in an interest-bearing account.

a) When $M \leq T$, the account is settled at $T = M$, the manufacturer pays off all units sold and keeps his/her profits, and starts paying for the higher interest payable on the items in stock with rate I_p .

b) When $T \leq M$, the account is settled at $T = M$ and the manufacturer does not need to pay any interest payable.

10) If a customer buys an item from the manufacturer at time $t \in [0, T]$, then the customer will have a trade credit period N and make the payment at time $N + t$.

11) The manufacturer can accumulate revenue and earn interest after his/her customer pays for the amount of purchasing cost to the manufacturer until the end of the trade credit period offered by the supplier. That is, the manufacturer can accumulate revenue and earn interest during the period N to M with rate I_e under the condition of trade credit.

12) The manufacturer keeps the profit for the use of the other activities.

2.3. Model

The model structure has three stages of a supply chain system, this paper supposes that the supplier provides raw materials to the manufacturer to produce, the quantity of raw materials is expected to decrease in time (from time 0 to t_s). On the other hand, the quantity of products is expected to increase in time up to the maximum inventory level (from 0 to t_s), also sold on demand. After production stops (at time t_s), the products are only sold on demand until quantity reaches zero (at time T), as shown in **Figure 1**.

3. The Annual Total Relevant Cost

The annual total relevant cost consists of the following element.

As shown in **Figure 1**, the raw material inventory level can be described by the following formulas, and we set the time in years at which production stops t_s , the optimal order size Q and storage maximum L_{\max} :

$$(P - D)t_s - D(T - t_s) = 0,$$

$$t_s = \frac{DT}{P}. \quad (1)$$

$$\frac{0 - Q}{t_s - 0} = -P, \quad 0 \leq t \leq T.$$

$$Q = Pt_s = DT. \quad (2)$$

$$L_{\max} = (P - D) \times t_s = DT\rho. \quad (3)$$

3.1. Annual Ordering Cost

Annual ordering cost

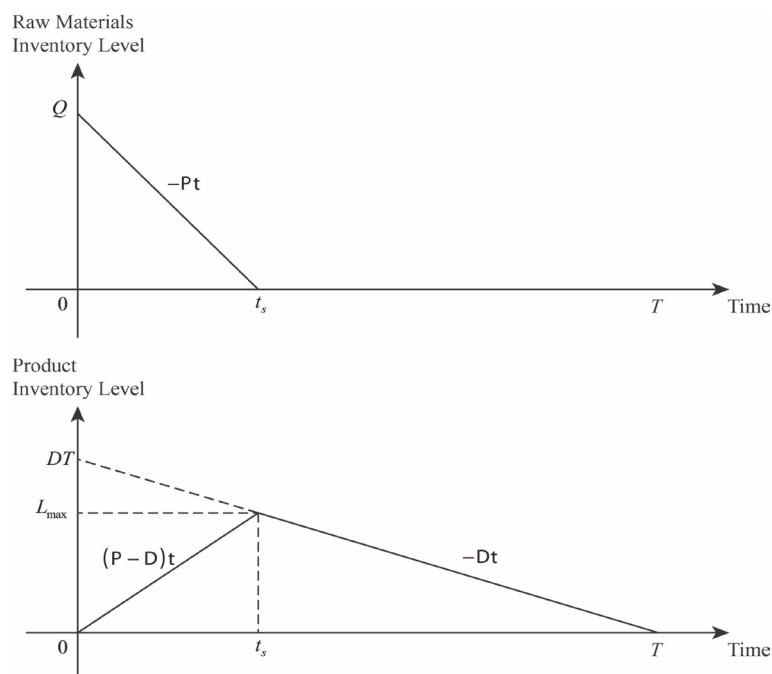

Figure 1. Raw materials and product inventory level.

$$= \frac{A}{T}. \quad (4)$$

3.2. Annual Purchasing Cost

Annual purchasing cost

$$= cQ \times \frac{1}{T} = cD. \quad (5)$$

3.3. Annual Holding Cost

Annual holding cost

1) As shown in **Figure 1**, annual holding cost of raw materials

$$= h_m \times \frac{Q \times t_s}{2} \times \frac{1}{T} = \frac{D^2 T h_m}{2P}. \quad (6)$$

2) Two cases occur in annual holding costs of owned warehouse.

a) $DT\rho \leq W$, as shown in **Figure 2**.

Annual holding cost in owned warehouse

$$= h_o \times \frac{T \times L_{\max}}{2} \times \frac{1}{T} = \frac{DT h_o \rho}{2}. \quad (7)$$

b) $DT\rho > W$, as shown in **Figure 3**.

Annual holding cost in owned warehouse

$$= h_o \times \frac{[(tw_d - tw_i) + T]W}{2} \times \frac{1}{T} = Wh_o - \frac{W^2 h_o}{2DT\rho}. \quad (8)$$

3) Two cases occur in annual holding costs of rented warehouse.

a) $DT\rho \leq W$, as shown in **Figure 2**.

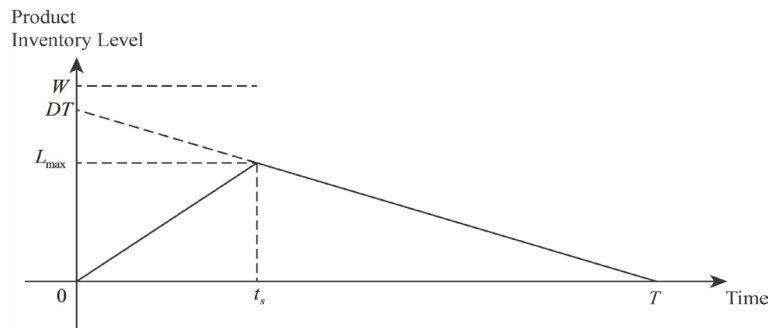

Figure 2. Annual holding cost when $DT\rho \leq W$.

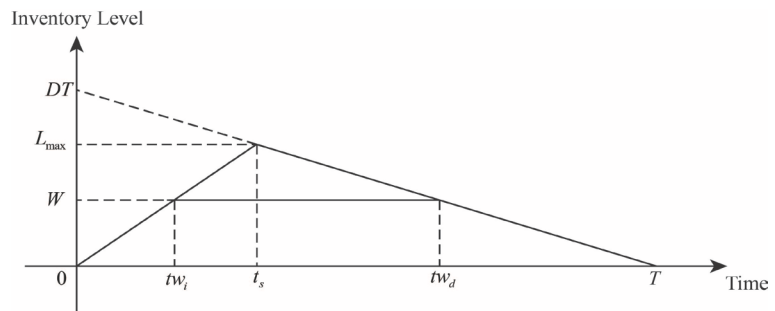

Figure 3. Annual holding cost when $DT\rho > W$.

Annual holding cost in rented warehouse

$$= 0. \tag{9}$$

b) $DT\rho > W$, as shown in **Figure 3**.

Annual holding cost in rented warehouse

$$= h_r \times \frac{(tw_d - tw_i) \times (L_{\max} - W)}{2} \times \frac{1}{T} = \frac{h_r (DT\rho - W)^2}{2DT\rho}. \tag{10}$$

3.4. Annual Interest Payable

Four cases to occur in costs of annual interest payable for the items kept in stock.

1) $0 \leq T < M - N$.

Annual interest payable

$$= 0. \tag{11}$$

2) $M - N \leq T < M$.

Annual interest payable

$$= 0. \tag{12}$$

3) $M \leq T < \frac{PM}{D}$, as shown in **Figure 4**

Annual interest payable

$$= cI_p \times \left(\frac{(T - M) \times D(T - M)}{2} \right) \times \frac{1}{T} = \frac{cI_p D(T - M)^2}{2T}. \tag{13}$$

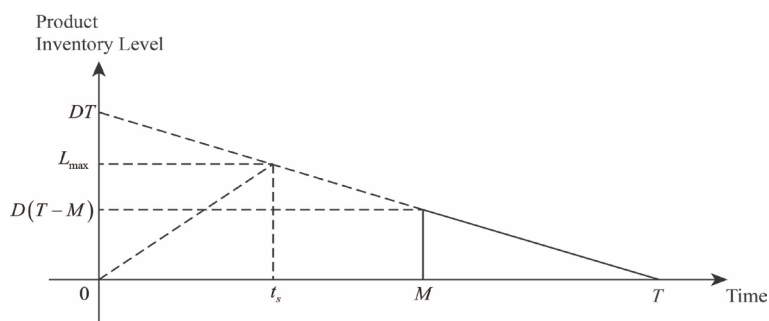

Figure 4. Annual interest payable when $M \leq T < \frac{PM}{D}$.

- 4) $\frac{PM}{D} \leq T$, as shown in **Figure 5**.

Annual interest payable

$$= cI_p \times \left(\frac{T \times DT \rho}{2} - \frac{M \times (P-D)M}{2} \right) \times \frac{1}{T} = \frac{cI_p \rho (DT^2 - PM^2)}{2T}. \quad (14)$$

3.5. Annual Interest Earned

Three cases to occur in annual interest earned.

- 1) $0 \leq T < N$, as shown in **Figure 6**.

Annual interest earned

$$= sI_e \times \left\{ \frac{[(T+N)-N] \times DT}{2} + [M - (T+N)] \times DT \right\} \times \frac{1}{T} \quad (15)$$

$$= \frac{sI_e D (2M - 2N - T)}{2}.$$

- 2) $N \leq T < M$, as shown in **Figure 7**.

Annual interest earned

$$= sI_e \times \left(\frac{(M-N) \times D(M-N)}{2} \right) \times \frac{1}{T} = \frac{sI_e D (M-N)^2}{2T}. \quad (16)$$

- 3) $M < T$, as shown in **Figure 8**.

Annual interest earned

$$= sI_e \times \left(\frac{(M-N) \times D(M-N)}{2} \right) \times \frac{1}{T} = \frac{sI_e D (M-N)^2}{2T}. \quad (17)$$

3.6. The Annual Total Relevant Cost

From the above arguments, the annual total relevant cost for the manufacturer can be expressed as $TRC(T)$ = annual ordering cost + annual purchasing cost + annual holding cost + annual interest payable + annual interest earned.

Because storage capacity $W = DT\rho$, there are four cases arise:

- 1) $\frac{W}{D\rho} < M - N$,

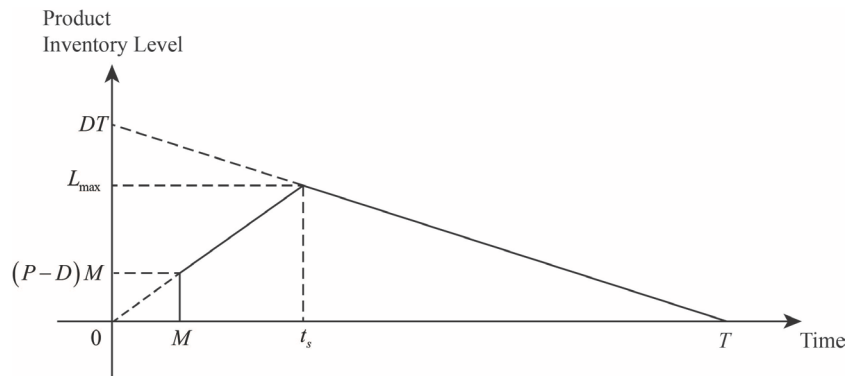

Figure 5. Annual interest payable when $\frac{PM}{D} \leq T$.

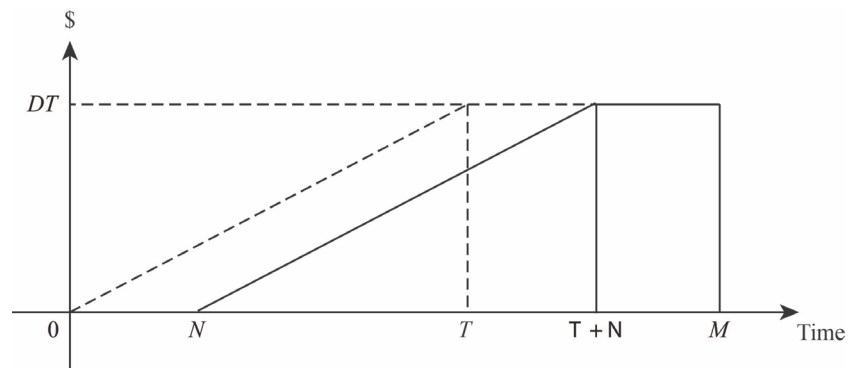

Figure 6. Annual interest earned when $0 \leq T < N$.

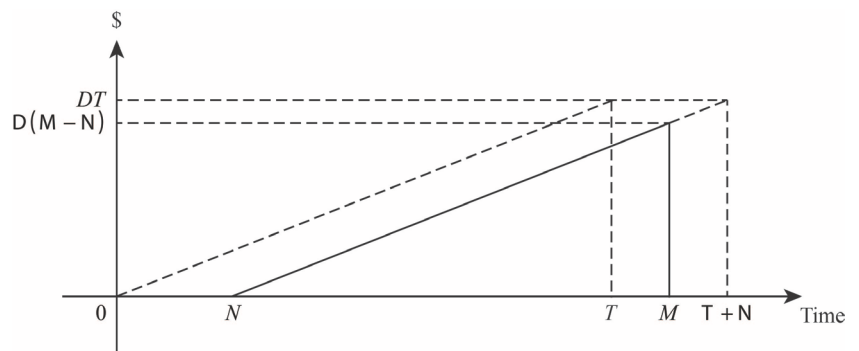

Figure 7. Annual interest earned when $N \leq T < M$.

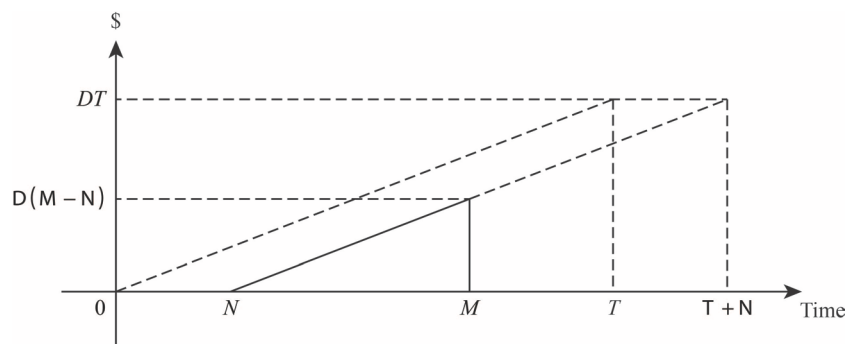

Figure 8. Annual interest earned when $M < T$.

$$2) M - N \leq \frac{W}{D\rho} < M,$$

$$3) M \leq \frac{W}{D\rho} < \frac{PM}{D},$$

$$4) \frac{PM}{D} \leq \frac{W}{D\rho}.$$

Case 1 $\frac{W}{D\rho} < M - N.$

According to Equations (1)-(17), the annual total relevant cost $TRC(T)$ can be expressed by

$$TRC(T) = \begin{cases} TRC_1(T), & \text{if } 0 < T < \frac{W}{D\rho} & (18a) \\ TRC_2(T), & \text{if } \frac{W}{D\rho} \leq T < M - N & (18b) \\ TRC_3(T), & \text{if } M - N \leq T < M & (18c) \\ TRC_4(T), & \text{if } M \leq T < \frac{PM}{D} & (18d) \\ TRC_5(T), & \text{if } \frac{PM}{D} \leq T & (18e) \end{cases}$$

where

$$TRC_1(T) = \frac{A}{T} + cD + \frac{D^2Th_m}{2P} + \frac{DTh_o\rho}{2} - \frac{sI_eD(2M - 2N - T)}{2}, \quad (19)$$

$$TRC_2(T) = \frac{A}{T} + cD + \frac{D^2Th_m}{2P} + Wh_o - \frac{W^2h_o}{2DT\rho} + \frac{h_r(DT\rho - W)^2}{2DT\rho} - \frac{sI_eD(2M - 2N - T)}{2}, \quad (20)$$

$$TRC_3(T) = \frac{A}{T} + cD + \frac{D^2Th_m}{2P} + Wh_o - \frac{W^2h_o}{2DT\rho} + \frac{h_r(DT\rho - W)^2}{2DT\rho} - \frac{sI_eD(M - N)^2}{2T}, \quad (21)$$

$$TRC_4(T) = \frac{A}{T} + cD + \frac{D^2Th_m}{2P} + Wh_o - \frac{W^2h_o}{2DT\rho} + \frac{h_r(DT\rho - W)^2}{2DT\rho} + \frac{cI_pD(T - M)^2}{2T} - \frac{sI_eD(M - N)^2}{2T}, \quad (22)$$

$$TRC_5(T) = \frac{A}{T} + cD + \frac{D^2Th_m}{2P} + Wh_o - \frac{W^2h_o}{2DT\rho} + \frac{h_r(DT\rho - W)^2}{2DT\rho} + \frac{cI_p\rho(DT^2 - PM^2)}{2T} - \frac{sI_eD(M - N)^2}{2T}. \quad (23)$$

Since $TRC_1\left(\frac{W}{D\rho}\right) = TRC_2\left(\frac{W}{D\rho}\right)$, $TRC_2(M - N) = TRC_3(M - N)$,

$TRC_3(M) = TRC_4(M)$, $TRC_4\left(\frac{PM}{D}\right) = TRC_5\left(\frac{PM}{D}\right)$, $TRC(T)$ is continuous at T , $T \in [0, \infty)$.

Case 2 $M - N \leq \frac{W}{D\rho} < M$.

According to Equations (1)-(17), the annual total relevant cost $TRC(T)$ can be expressed by

$$TRC(T) = \begin{cases} TRC_1(T), & \text{if } 0 < T < M - N & (24a) \\ TRC_6(T), & \text{if } M - N \leq T < \frac{W}{D\rho} & (24b) \\ TRC_3(T), & \text{if } M \leq T < \frac{PM}{D} & (24c) \\ TRC_4(T), & \text{if } M \leq T < \frac{PM}{D} & (24d) \\ TRC_5(T), & \text{if } \frac{PM}{D} \leq T & (24e) \end{cases}$$

where

$$TRC_6(T) = \frac{A}{T} + cD + \frac{D^2Th_m}{2P} + \frac{DTh_o\rho}{2} - \frac{sI_eD(M-N)^2}{2T}. \quad (25)$$

Since $TRC_1(M - N) = TRC_6(M - N)$, $TRC_6\left(\frac{W}{D\rho}\right) = TRC_3\left(\frac{W}{D\rho}\right)$, $TRC_3(M) = TRC_4(M)$, $TRC_4\left(\frac{PM}{D}\right) = TRC_5\left(\frac{PM}{D}\right)$, $TRC(T)$ is continuous at T , $T \in [0, \infty)$.

Case 3 $M \leq \frac{W}{D\rho} < \frac{PM}{D}$.

According to Equations (1)-(17), the annual total relevant cost $TRC(T)$ can be expressed by

$$TRC(T) = \begin{cases} TRC_1(T), & \text{if } 0 < T < M - N & (26a) \\ TRC_6(T), & \text{if } M - N \leq T < M & (26b) \\ TRC_7(T), & \text{if } M \leq T < \frac{W}{D\rho} & (26c) \\ TRC_4(T), & \text{if } \frac{W}{D\rho} \leq T < \frac{PM}{D} & (26d) \\ TRC_5(T), & \text{if } \frac{PM}{D} \leq T & (26e) \end{cases}$$

where

$$TRC_7(T) = \frac{A}{T} + cD + \frac{D^2Th_m}{2P} + \frac{DTh_o\rho}{2} + \frac{cI_pD(T-M)^2}{2T} - \frac{sI_eD(M-N)^2}{2T}. \quad (27)$$

Since $TRC_1(M - N) = TRC_6(M - N)$, $TRC_6(M) = TRC_7(M)$, $TRC_7\left(\frac{W}{D\rho}\right) = TRC_4\left(\frac{W}{D\rho}\right)$, $TRC_4\left(\frac{PM}{D}\right) = TRC_5\left(\frac{PM}{D}\right)$, $TRC(T)$ is

continuous at T , $T \in [0, \infty)$.

$$\text{Case 4 } \frac{PM}{D} \leq \frac{W}{D\rho}.$$

According to Equations (1)-(17), the annual total relevant cost $TRC(T)$ can be expressed by

$$TRC(T) = \begin{cases} TRC_1(T), & \text{if } 0 < T < M - N & (28a) \\ TRC_6(T), & \text{if } M - N \leq T < M & (28b) \\ TRC_7(T), & \text{if } M \leq T < \frac{PM}{D} & (28c) \\ TRC_8(T), & \text{if } \frac{PM}{D} \leq T < \frac{W}{D\rho} & (28d) \\ TRC_5(T), & \text{if } \frac{W}{D\rho} \leq T & (28e) \end{cases}$$

where

$$TRC_8(T) = \frac{A}{T} + cD + \frac{D^2Th_m}{2P} + \frac{DTh_o\rho}{2} + \frac{cI_p\rho(DT^2 - PM^2)}{2T} - \frac{sI_eD(M - N)^2}{2T}. \quad (29)$$

Since $TRC_1(M - N) = TRC_6(M - N)$, $TRC_6(M) = TRC_7(M)$, $TRC_7\left(\frac{PM}{D}\right) = TRC_8\left(\frac{PM}{D}\right)$, $TRC_8\left(\frac{W}{D\rho}\right) = TRC_5\left(\frac{W}{D\rho}\right)$, $TRC(T)$ is continuous at T , $T \in [0, \infty)$.

In summary, all $TRC_i(T)$ ($i = 1 \sim 8$) are defined on $T > 0$.

4. The Convexity of $TRC_i(T)$ ($i = 1 \sim 8$)

Equations (19)-(23), (25), (27) and (29) yield the first order and second-order derivatives as follows.

$$TRC_1'(T) = \frac{-A}{T^2} + \frac{D}{2} \left(\frac{D}{P} h_m + \rho h_o + sI_e \right), \quad (30)$$

$$TRC_1''(T) = \frac{2A}{T^3} > 0, \quad (31)$$

$$TRC_2'(T) = \frac{-2A + \frac{W^2(h_o - h_r)}{D\rho}}{2T^2} + \frac{D}{2} \left(\frac{D}{P} h_m + \rho h_r + sI_e \right), \quad (32)$$

$$TRC_2''(T) = \frac{2A + \frac{W^2(h_r - h_o)}{D\rho}}{T^3} > 0, \quad (33)$$

$$TRC_3'(T) = \frac{-2A + \frac{W^2(h_o - h_r)}{D\rho} + sI_eD(M - N)^2}{2T^2} + \frac{D}{2} \left(\frac{D}{P} h_m + \rho h_r \right), \quad (34)$$

$$TRC_3''(T) = \frac{2A + \frac{W^2(h_r - h_o)}{D\rho} - sI_e D(M - N)^2}{T^3}, \quad (35)$$

$$TRC_4'(T) = \frac{-2A + \frac{W^2(h_o - h_r)}{D\rho} - cI_p DM^2 + sI_e D(M - N)^2}{2T^2} + \frac{D}{2} \left(\frac{D}{P} h_m + \rho h_r + cI_p \right), \quad (36)$$

$$TRC_4''(T) = \frac{2A + \frac{W^2(h_r - h_o)}{D\rho} + cI_p DM^2 - sI_e D(M - N)^2}{T^3}, \quad (37)$$

$$TRC_5'(T) = \frac{-2A + \frac{W^2(h_o - h_r)}{D\rho} + cI_p (P - D)M^2 + sI_e D(M - N)^2}{2T^2} + \frac{D}{2} \left(\frac{D}{P} h_m + \rho(h_r + cI_p) \right), \quad (38)$$

$$TRC_5''(T) = \frac{2A + \frac{W^2(h_r - h_o)}{D\rho} - cI_p (P - D)M^2 - sI_e D(M - N)^2}{T^3}, \quad (39)$$

$$TRC_6'(T) = \frac{-2A + sI_e D(M - N)^2}{2T^2} + \frac{D}{2} \left(\frac{D}{P} h_m + \rho h_o \right), \quad (40)$$

$$TRC_6''(T) = \frac{2A - sI_e D(M - N)^2}{T^3}, \quad (41)$$

$$TRC_7'(T) = \frac{-2A - cI_p DM^2 + sI_e D(M - N)^2}{2T^2} + \frac{D}{2} \left(\frac{D}{P} h_m + \rho h_o + cI_p \right), \quad (42)$$

$$TRC_7''(T) = \frac{2A + cI_p DM^2 - sI_e D(M - N)^2}{T^3}, \quad (43)$$

$$TRC_8'(T) = \frac{-2A + c_p (P - D)M^2 + sI_e D(M - N)^2}{2T^2} + \frac{D}{2} \left(\frac{D}{P} h_m + \rho(h_o + cI_p) \right), \quad (44)$$

and

$$TRC_8''(T) = \frac{2A - c_p (P - D)M^2 - sI_e D(M - N)^2}{T^3}. \quad (45)$$

Let

$$G_3 = 2A + \frac{W^2(h_r - h_o)}{D\rho} - sI_e D(M - N)^2, \quad (46)$$

$$G_4 = 2A + \frac{W^2(h_r - h_o)}{D\rho} + cI_p DM^2 - sI_e D(M - N)^2, \quad (47)$$

$$G_5 = 2A + \frac{W^2(h_r - h_o)}{D\rho} - cI_p(P-D)M^2 - sI_eD(M-N)^2, \quad (48)$$

$$G_6 = 2A - sI_eD(M-N)^2, \quad (49)$$

$$G_7 = 2A + cI_pDM^2 - sI_eD(M-N)^2, \quad (50)$$

and

$$G_8 = 2A - c_p(P-D)M^2 - sI_eD(M-N)^2. \quad (51)$$

Equations (46)-(51) imply

$$G_4 > G_3 > G_5 > G_8, \quad (52)$$

and

$$G_4 > G_7 > G_6 > G_8. \quad (53)$$

Equations (30)-(45) reveal the following results.

Lemma 1

- 1) $TRC_i(T)$ is convex on $T > 0$ if $i=1,2$.
- 2) $TRC_i(T)$ is convex on $T > 0$ if $G_i > 0$. Otherwise $TRC'_i(T)$ is increasing on $T > 0$ for all $i=3 \sim 8$.

Solving

$$TRC'_i(T) = 0, i=1 \sim 8 \quad (54)$$

then

$$T_1^* = \sqrt{\frac{2A}{D\left(\frac{D}{P}h_m + \rho h_o + sI_e\right)}}, \quad (55)$$

$$T_2^* = \sqrt{\frac{2A + \frac{W^2(h_r - h_o)}{D\rho}}{D\left(\frac{D}{P}h_m + \rho h_r + sI_e\right)}}, \quad (56)$$

$$T_3^* = \sqrt{\frac{2A + \frac{W^2(h_r - h_o)}{D\rho} - sI_eD(M-N)^2}{D\left(\frac{D}{P}h_m + \rho h_r\right)}}, \text{ if } G_3 > 0, \quad (57)$$

$$T_4^* = \sqrt{\frac{2A + \frac{W^2(h_r - h_o)}{D\rho} + cI_pDM^2 - sI_eD(M-N)^2}{D\left(\frac{D}{P}h_m + \rho h_r + cI_p\right)}}, \text{ if } G_4 > 0, \quad (58)$$

$$T_5^* = \sqrt{\frac{2A + \frac{W^2(h_r - h_o)}{D\rho} - cI_p(P-D)M^2 - sI_eD(M-N)^2}{D\left(\frac{D}{P}h_m + \rho(h_r + cI_p)\right)}}, \text{ if } G_5 > 0, \quad (59)$$

$$T_6^* = \frac{\sqrt{2A - sI_e D(M-N)^2}}{\sqrt{D\left(\frac{D}{P}h_m + \rho h_o\right)}}, \text{ if } G_6 > 0, \quad (60)$$

$$T_7^* = \frac{\sqrt{2A + cI_p DM^2 - sI_e D(M-N)^2}}{\sqrt{D\left(\frac{D}{P}h_m + \rho h_o + cI_p\right)}}, \text{ if } G_7 > 0, \quad (61)$$

and

$$T_8^* = \frac{\sqrt{2A - cI_p(P-D)M^2 - sI_e D(M-N)^2}}{\sqrt{D\left(\frac{D}{P}h_m + \rho(h_o + cI_p)\right)}}, \text{ if } G_8 > 0, \quad (62)$$

are the respective solutions of Equation (54). Furthermore, if T_i^* exists, then $TRC_i(T)$ is convex on $T > 0$ and

$$TRC'_i(T) = \begin{cases} < 0 & \text{if } 0 < T < T_i^* \\ = 0 & \text{if } T = T_i^* \\ > 0 & \text{if } T_i^* < T \end{cases} \quad (63a)$$

$$= 0 \quad \text{if } T = T_i^* \quad (63b)$$

$$> 0 \quad \text{if } T_i^* < T \quad (63c)$$

Equations (63a)-(63c) imply that $TRC_i(T)$ is decreasing on $(0, T_i^*]$ and increasing on $[T_i^*, \infty)$ for all $i = 1 \sim 8$.

5. Numbers Δ_{ij}

Case 1 $\frac{W}{D\rho} < M - N$.

Equations (30), (32), (34), (36) and (38) yield

$$TRC'_1\left(\frac{W}{D\rho}\right) = TRC'_2\left(\frac{W}{D\rho}\right) = \frac{\Delta_{12}}{2\left(\frac{W}{D\rho}\right)^2}, \quad (64)$$

$$TRC'_2(M - N) = TRC'_3(M - N) = \frac{\Delta_{23}}{2(M - N)^2}, \quad (65)$$

$$TRC'_3(M) = TRC'_4(M) = \frac{\Delta_{34}}{2M^2}, \quad (66)$$

$$TRC'_4\left(\frac{PM}{D}\right) = TRC'_5\left(\frac{PM}{D}\right) = \frac{\Delta_{45}}{2\left(\frac{PM}{D}\right)^2}, \quad (67)$$

where

$$\Delta_{12} = -2A + D\left(\frac{W}{D\rho}\right)^2\left(\frac{D}{P}h_m + \rho h_o + sI_e\right), \quad (68)$$

$$\Delta_{23} = -2A + \frac{W^2(h_o - h_r)}{D\rho} + D(M - N)^2\left(\frac{D}{P}h_m + \rho h_r + sI_e\right), \quad (69)$$

$$\Delta_{34} = -2A + \frac{W^2(h_o - h_r)}{D\rho} + sI_e D(M - N)^2 + DM^2 \left(\frac{D}{P} h_m + \rho h_r \right), \quad (70)$$

$$\begin{aligned} \Delta_{45} = & -2A + \frac{W^2(h_o - h_r)}{D\rho} - cI_p DM^2 + sI_e (M - N)^2 \\ & + D \left(\frac{PM}{D} \right)^2 \left(\frac{D}{P} h_m + \rho h_r + cI_p \right). \end{aligned} \quad (71)$$

Equations (68)-(71) imply

$$\Delta_{12} < \Delta_{23} < \Delta_{34} < \Delta_{45}. \quad (72)$$

Case 2 $M - N \leq \frac{W}{D\rho} < M$.

Equations (30), (34), (36), (38) and (40) yield

$$TRC'_1(M - N) = TRC'_6(M - N) = \frac{\Delta_{16}}{2(M - N)^2}, \quad (73)$$

$$TRC'_6\left(\frac{W}{D\rho}\right) = TRC'_3\left(\frac{W}{D\rho}\right) = \frac{\Delta_{63}}{2\left(\frac{W}{D\rho}\right)^2}, \quad (74)$$

$$TRC'_3(M) = TRC'_4(M) = \frac{\Delta_{34}}{2M^2}, \quad (75)$$

$$TRC'_4\left(\frac{PM}{D}\right) = TRC'_5\left(\frac{PM}{D}\right) = \frac{\Delta_{45}}{2\left(\frac{PM}{D}\right)^2}, \quad (76)$$

where

$$\Delta_{16} = -2A + D(M - N)^2 \left(\frac{D}{P} h_m + \rho h_o + sI_e \right), \quad (77)$$

$$\Delta_{63} = -2A + sI_e D(M - N)^2 + D \left(\frac{W}{D\rho} \right)^2 \left(\frac{D}{P} h_m + \rho h_o \right). \quad (78)$$

Equations (70), (71), (77) and (78) imply

$$\Delta_{16} \leq \Delta_{63} < \Delta_{34} < \Delta_{45}. \quad (79)$$

Case 3 $M \leq \frac{W}{D\rho} < \frac{PM}{D}$.

Equations (30), (36), (38), (40) and (42) yield

$$TRC'_1(M - N) = TRC'_6(M - N) = \frac{\Delta_{16}}{2(M - N)^2}, \quad (80)$$

$$TRC'_6(M) = TRC'_7(M) = \frac{\Delta_{67}}{2M^2}, \quad (81)$$

$$TRC'_7\left(\frac{W}{D\rho}\right) = TRC'_4\left(\frac{W}{D\rho}\right) = \frac{\Delta_{74}}{2\left(\frac{W}{D\rho}\right)^2}, \quad (82)$$

$$TRC'_4\left(\frac{PM}{D}\right) = TRC'_5\left(\frac{PM}{D}\right) = \frac{\Delta_{45}}{2\left(\frac{PM}{D}\right)^2}, \quad (83)$$

where

$$\Delta_{67} = -2A + sI_e D(M - N)^2 + DM^2\left(\frac{D}{P}h_m + \rho h_o\right), \quad (84)$$

$$\Delta_{74} = -2A - cI_p DM^2 + sI_e D(M - N)^2 + D\left(\frac{W}{D\rho}\right)^2\left(\frac{D}{P}h_m + \rho h_o + cI_p\right). \quad (85)$$

Equations (71), (77), (84) and (85) imply

$$\Delta_{16} \leq \Delta_{67} \leq \Delta_{74} < \Delta_{45}. \quad (86)$$

Case 4 $\frac{PM}{D} \leq \frac{W}{D\rho}$.

Equations (30), (38), (40), (42) and (44) yield

$$TRC'_1(M - N) = TRC'_6(M - N) = \frac{\Delta_{16}}{2(M - N)^2}, \quad (87)$$

$$TRC'_6(M) = TRC'_7(M) = \frac{\Delta_{67}}{2M^2}, \quad (88)$$

$$TRC'_7\left(\frac{PM}{D}\right) = TRC'_8\left(\frac{PM}{D}\right) = \frac{\Delta_{78}}{2\left(\frac{PM}{D}\right)^2}, \quad (89)$$

$$TRC'_8\left(\frac{W}{D\rho}\right) = TRC'_5\left(\frac{W}{D\rho}\right) = \frac{\Delta_{45}}{2\left(\frac{W}{D\rho}\right)^2}, \quad (90)$$

where

$$\begin{aligned} \Delta_{78} = & -2A - cI_p DM^2 + sI_e D(M - N)^2 \\ & + D\left(\frac{PM}{D}\right)^2\left(\frac{D}{P}h_m + \rho h_o + cI_p\right), \end{aligned} \quad (91)$$

$$\begin{aligned} \Delta_{85} = & -2A + cI_p (P - D)M^2 + sI_e D(M - N)^2 \\ & + D\left(\frac{W}{D\rho}\right)^2\left(\frac{D}{P}h_m + \rho(h_o + cI_p)\right). \end{aligned} \quad (92)$$

Equations (77), (84), (91) and (92) imply

$$\Delta_{16} \leq \Delta_{67} \leq \Delta_{78} \leq \Delta_{85}. \quad (93)$$

Based on the above arguments, the following results hold.

Lemma 2

A) If $\Delta_{23} \leq 0$, then

(a1) $G_3 > 0$,

(a2) T_3^* exists,

(a3) $TRC_3(T)$ is convex on $T > 0$.

- B) If $\Delta_{34} \leq 0$, then
- (b1) $G_3 > 0$ and $G_4 > 0$,
 - (b2) T_3^* and T_4^* exist,
 - (b3) $TRC_3(T)$ and $TRC_4(T)$ are convex on $T > 0$.
- C) If $\Delta_{45} \leq 0$, then
- (c1) $G_4 > 0$ and $G_5 > 0$,
 - (c2) T_4^* and T_5^* exist,
 - (c3) $TRC_4(T)$ and $TRC_5(T)$ are convex on $T > 0$.
- D) If $\Delta_{85} \leq 0$, then
- (d1) $G_5 > 0$ and $G_8 > 0$,
 - (d2) T_5^* and T_8^* exist,
 - (d3) $TRC_5(T)$ and $TRC_8(T)$ are convex on $T > 0$.
- E) If $\Delta_{16} \leq 0$, then
- (e1) $G_6 > 0$,
 - (e2) T_6^* exists,
 - (e3) $TRC_6(T)$ is convex on $T > 0$.
- F) If $\Delta_{67} \leq 0$, then
- (f1) $G_6 > 0$ and $G_7 > 0$,
 - (f2) T_6^* and T_7^* exist,
 - (f3) $TRC_6(T)$ and $TRC_7(T)$ are convex on $T > 0$.
- G) If $\Delta_{74} \leq 0$, then
- (g1) $G_4 > 0$ and $G_7 > 0$,
 - (g2) T_4^* and T_7^* exist,
 - (g3) $TRC_4(T)$ and $TRC_7(T)$ are convex on $T > 0$.
- H) If $\Delta_{78} \leq 0$, then
- (h1) $G_7 > 0$ and $G_8 > 0$,
 - (h2) T_7^* and T_8^* exist,
 - (h3) $TRC_7(T)$ and $TRC_8(T)$ are convex on $T > 0$.

Proof. A) (a1) If $\Delta_{23} \leq 0$, then

$$2A \geq \frac{W^2(h_o - h_r)}{D\rho} + D(M - N)^2 \left(\frac{D}{P} h_m + \rho h_r + sI_e \right). \quad (94)$$

Equation (94) implies

$$G_3 \geq D(M - N)^2 \left(\frac{D}{P} h_m + \rho h_r \right) > 0. \quad (95)$$

(a2) Equation (57) and Lemma 1 imply that T_3^* exists.

(a3) Equation (35) and Lemma 1 imply that $TRC_3(T)$ is convex on $T > 0$.

B) (b1) If $\Delta_{34} \leq 0$, then

$$2A \geq \frac{W^2(h_o - h_r)}{D\rho} + sI_e D(M - N)^2 + DM^2 \left(\frac{D}{P} h_m + \rho h_r \right). \quad (96)$$

Equation (96) implies

$$G_3 \geq DM^2 \left(\frac{D}{P} h_m + \rho h_r + cI_p \right) > 0. \quad (97)$$

Equations (52) and (97) demonstrate $G_4 > G_3 > 0$.

(b2) Equations (57), (58) and Lemma 1 imply that T_3^* and T_4^* exist.

(b3) Equations (35), (37) and Lemma 1 imply that $TRC_3(T)$ and $TRC_4(T)$ is convex on $T > 0$.

C) (c1) If $\Delta_{45} \leq 0$, then

$$2A \geq \frac{W^2(h_o - h_r)}{D\rho} - cI_p DM^2 + sI_e(M - N)^2 + D\left(\frac{PM}{D}\right)^2 \left(\frac{D}{P}h_m + \rho h_r + cI_p\right). \quad (98)$$

Equation (98) implies

$$G_5 \geq D\left(\frac{PM}{D}\right)^2 \left(\frac{D}{P}h_m + \rho(h_r + cI_p)\right) > 0. \quad (99)$$

Equations (52) and (99) demonstrate $G_4 > G_5 > 0$.

(c2) Equations (58), (59) and Lemma 1 imply that T_4^* and T_5^* exist.

(c3) Equations (37), (39) and Lemma 1 imply that $TRC_4(T)$ and $TRC_5(T)$ are convex on $T > 0$.

D) (d1) If $\Delta_{85} \leq 0$, then

$$2A \geq cI_p(P - D)M^2 + sI_e D(M - N)^2 + D\left(\frac{W}{D\rho}\right)^2 \left(\frac{D}{P}h_m + \rho(h_o + cI_p)\right), \quad (100)$$

Equation (100) implies

$$G_8 \geq D\left(\frac{W}{D\rho}\right)^2 \left(\frac{D}{P}h_m + \rho(h_o + cI_p)\right) > 0. \quad (101)$$

Equations (52) and (101) demonstrate $G_5 > G_8 > 0$.

(d2) Equations (59), (62) and Lemma 1 imply that T_5^* and T_8^* exist.

(d3) Equations (39), (45) and Lemma 1 imply that $TRC_5(T)$ and $TRC_8(T)$ are convex on $T > 0$.

E) (e1) If $\Delta_{16} \leq 0$, then

$$2A \geq D(M - N)^2 \left(\frac{D}{P}h_m + \rho h_o + sI_e\right). \quad (102)$$

Equation (102) implies

$$G_6 \geq D(M - N)^2 \left(\frac{D}{P}h_m + \rho h_o\right) > 0. \quad (103)$$

(e2) Equations (60) and Lemma 1 imply that T_6^* exists.

(e3) Equations (41) and Lemma 1 imply that $TRC_6(T)$ is convex on $T > 0$.

F) (f1) If $\Delta_{67} \leq 0$, then

$$2A \geq DM^2(sI_e - cI_p) - sI_e DN^2 + D\left(\frac{PM}{D}\right)^2 \left(\frac{D}{P}h_m + \rho h_o + cI_p\right). \quad (104)$$

Equation (104) implies

$$G_7 \geq D \left(\frac{PM}{D} \right)^2 \left(\frac{D}{P} h_m + \rho h_o + cI_p \right) > 0. \quad (105)$$

Equations (53) and (105) demonstrate $G_7 > G_6 > 0$.

(f2) Equations (60), (61) and Lemma 1 imply that T_6^* and T_7^* exist.

(f3) Equations (41), (43) and Lemma 1 imply that $TRC_6(T)$ and $TRC_7(T)$ are convex on $T > 0$.

G) (g1) If $\Delta_{74} \leq 0$, then

$$2A \geq -cI_p DM^2 + sI_e D(M-N)^2 + D \left(\frac{W}{D\rho} \right)^2 \left(\frac{D}{P} h_m + \rho h_o + cI_p \right). \quad (106)$$

Equation (106) implies

$$G_4 \geq \frac{W^2(h_r - h_o)}{D\rho} + D \left(\frac{W}{D\rho} \right)^2 \left(\frac{D}{P} h_m + \rho h_o + cI_p \right) > 0. \quad (107)$$

Equations (53) and (107) demonstrate $G_4 > G_7 > 0$.

(g2) Equations (58), (61) and Lemma 1 imply that T_4^* and T_7^* exist.

(g3) Equations (37), (43) and Lemma 1 imply that $TRC_4(T)$ and $TRC_7(T)$ are convex on $T > 0$.

H) (h1) If $\Delta_{78} \leq 0$, then

$$2A \geq -cI_p DM^2 + sI_e D(M-N)^2 + D \left(\frac{PM}{D} \right)^2 \left(\frac{D}{P} h_m + \rho h_r + cI_p \right). \quad (108)$$

Equation (108) implies

$$G_8 \geq D \left(\frac{PM}{D} \right)^2 \left(\frac{D}{P} h_m + \rho(h_r + cI_p) \right) > 0. \quad (109)$$

Equations (53) and (109) demonstrate $G_7 > G_8 > 0$.

(h2) Equations (61), (62) and Lemma 1 imply that T_7^* and T_8^* exist.

(h3) Equations (43), (45) and Lemma 1 imply that $TRC_7(T)$ and $TRC_8(T)$ are convex on $T > 0$.

Incorporate the above arguments, we have completed the proof of Lemma 2. \square

6. The Determination of the Optimal Cycle Time T^* of $TRC(T)$

Theorem 1 Suppose $\frac{W}{D\rho} < M - N$. Hence,

A) if $0 < \Delta_{12}$, then $TRC(T^*) = TRC_1(T_1^*)$ and $T^* = T_1^*$.

B) if $\Delta_{12} \leq 0 < \Delta_{23}$, then $TRC(T^*) = TRC_2(T_2^*)$ and $T^* = T_2^*$.

C) if $\Delta_{23} \leq 0 < \Delta_{34}$, then $TRC(T^*) = TRC_3(T_3^*)$ and $T^* = T_3^*$.

D) if $\Delta_{34} \leq 0 < \Delta_{45}$, then $TRC(T^*) = TRC_4(T_4^*)$ and $T^* = T_4^*$.

E) if $\Delta_{45} \leq 0$, then $TRC(T^*) = TRC_5(T_5^*)$ and $T^* = T_5^*$.

Proof. A) If $0 < \Delta_{12}$, then $0 < \Delta_{12} < \Delta_{23} < \Delta_{34} < \Delta_{45}$. So, Equations (63a)-(63c), lemma 1 and 2 imply

(a1) $TRC_1(T)$ is decreasing on $(0, T_1^*]$ and increasing on $\left[T_1^*, \frac{W}{D\rho} \right]$.

(a2) $TRC_2(T)$ is increasing on $\left[\frac{W}{D\rho}, M-N\right]$.

(a3) $TRC_3(T)$ is increasing on $[M-N, M]$.

(a4) $TRC_4(T)$ is increasing on $\left[M, \frac{PM}{D}\right]$.

(a5) $TRC_5(T)$ is increasing on $\left[\frac{PM}{D}, \infty\right)$.

Since $TRC(T)$ is continuous on $T > 0$, Equations (18a)-(18e) and (a1)-(a5) reveal that $TRC(T)$ is decreasing on $(0, T_1^*]$ and increasing on $[T_1^*, \infty)$. Hence, $T^* = T_1^*$ and $TRC(T^*) = TRC_1(T_1^*)$.

B) If $\Delta_{12} \leq 0 < \Delta_{23}$, then $\Delta_{12} \leq 0 < \Delta_{23} < \Delta_{34} < \Delta_{45}$. So, Equations (63a)-(63c), lemma 1 and 2 imply

(b1) $TRC_1(T)$ is decreasing on $\left[0, \frac{W}{D\rho}\right]$.

(b2) $TRC_2(T)$ is decreasing on $\left[\frac{W}{D\rho}, T_2^*\right]$ and increasing on $[T_2^*, M-N]$.

(b3) $TRC_3(T)$ is increasing on $[M-N, M]$.

(b4) $TRC_4(T)$ is increasing on $\left[M, \frac{PM}{D}\right]$.

(b5) $TRC_5(T)$ is increasing on $\left[\frac{PM}{D}, \infty\right)$.

Since $TRC(T)$ is continuous on $T > 0$, Equations (18a)-(18e) and (b1)-(b5) reveal that $TRC(T)$ is decreasing on $(0, T_2^*]$ and increasing on $[T_2^*, \infty)$. Hence, $T^* = T_2^*$ and $TRC(T^*) = TRC_2(T_2^*)$.

C) If $\Delta_{23} \leq 0 < \Delta_{34}$, then $\Delta_{12} < \Delta_{23} \leq 0 < \Delta_{34} < \Delta_{45}$. So, Equations (63a)-(63c), lemma 1 and 2 imply

(c1) $TRC_1(T)$ is decreasing on $\left[0, \frac{W}{D\rho}\right]$.

(c2) $TRC_2(T)$ is decreasing on $\left[\frac{W}{D\rho}, M-N\right]$.

(c3) $TRC_3(T)$ is decreasing on $[M-N, T_3^*]$ and increasing on $[T_3^*, M]$.

(c4) $TRC_4(T)$ is increasing on $\left[M, \frac{PM}{D}\right]$.

(c5) $TRC_5(T)$ is increasing on $\left[\frac{PM}{D}, \infty\right)$.

Since $TRC(T)$ is continuous on $T > 0$, Equations (18a)-(18c) and (c1)-(c5) reveal that $TRC(T)$ is decreasing on $(0, T_3^*]$ and increasing on $[T_3^*, \infty)$. Hence, $T^* = T_3^*$ and $TRC(T^*) = TRC_3(T_3^*)$.

D) If $\Delta_{34} \leq 0 < \Delta_{45}$, then $\Delta_{12} < \Delta_{23} < \Delta_{34} \leq 0 < \Delta_{45}$. So, Equations (63a)-(63c), lemma 1 and 2 imply

(d1) $TRC_1(T)$ is decreasing on $\left[0, \frac{W}{D\rho}\right]$.

(d2) $TRC_2(T)$ is decreasing on $\left[\frac{W}{D\rho}, M-N\right]$.

(d3) $TRC_3(T)$ is decreasing on $[M-N, M]$.

(d4) $TRC_4(T)$ is decreasing on $[M, T_4^*]$ and increasing on $\left[T_4^*, \frac{PM}{D}\right]$.

(d5) $TRC_5(T)$ is increasing on $\left[\frac{PM}{D}, \infty\right)$.

Since $TRC(T)$ is continuous on $T > 0$, Equations (18a)-(18e) and (d1)-(d5) reveal that $TRC(T)$ is decreasing on $(0, T_4^*]$ and increasing on $[T_4^*, \infty)$. Hence, $T^* = T_4^*$ and $TRC(T^*) = TRC_4(T_4^*)$.

E) If $\Delta_{45} \leq 0$, then $\Delta_{12} < \Delta_{23} < \Delta_{34} < \Delta_{45} \leq 0$. So, Equations (63a)-(63c), lemma 1 and 2 imply

(e1) $TRC_1(T)$ is decreasing on $\left[0, \frac{W}{D\rho}\right]$.

(e2) $TRC_2(T)$ is decreasing on $\left[\frac{W}{D\rho}, M-N\right]$.

(e3) $TRC_3(T)$ is decreasing on $[M-N, M]$.

(e4) $TRC_4(T)$ is decreasing on $[M, T_4^*]$.

(e5) $TRC_5(T)$ is decreasing on $\left[\frac{PM}{D}, T_5^*\right]$ and increasing on $[T_5^*, \infty)$.

Since $TRC(T)$ is continuous on $T > 0$, Equations (18a)-(18e) and (d1)-(d5) reveal that $TRC(T)$ is decreasing on $(0, T_5^*]$ and increasing on $[T_5^*, \infty)$. Hence, $T^* = T_5^*$ and $TRC(T^*) = TRC_5(T_5^*)$.

Incorporating all the above arguments, we have completed the proof of Theorem 1. \square

Applying Lemmas 1, 2 and Equations (24a)-(24e), the following results hold.

Theorem 2 Suppose $M-N \leq \frac{W}{D\rho} < M$. Hence,

A) if $0 < \Delta_{16}$, then $TRC(T^*) = TRC_1(T_1^*)$ and $T^* = T_1^*$.

B) if $\Delta_{16} \leq 0 < \Delta_{63}$, then $TRC(T^*) = TRC_6(T_6^*)$ and $T^* = T_6^*$.

C) if $\Delta_{63} \leq 0 < \Delta_{34}$, then $TRC(T^*) = TRC_3(T_3^*)$ and $T^* = T_3^*$.

D) if $\Delta_{34} \leq 0 < \Delta_{45}$, then $TRC(T^*) = TRC_4(T_4^*)$ and $T^* = T_4^*$.

E) if $\Delta_{45} \leq 0$, then $TRC(T^*) = TRC_5(T_5^*)$ and $T^* = T_5^*$.

Applying Lemmas 1, 2 and Equations (26a)-(26e), the following results hold.

Theorem 3 Suppose $M \leq \frac{W}{D\rho} < \frac{PM}{D}$. Hence,

A) if $0 < \Delta_{16}$, then $TRC(T^*) = TRC_1(T_1^*)$ and $T^* = T_1^*$.

B) if $\Delta_{16} \leq 0 < \Delta_{67}$, then $TRC(T^*) = TRC_6(T_6^*)$ and $T^* = T_6^*$.

C) if $\Delta_{67} \leq 0 < \Delta_{74}$, then $TRC(T^*) = TRC_7(T_7^*)$ and $T^* = T_7^*$.

D) if $\Delta_{74} \leq 0 < \Delta_{45}$, then $TRC(T^*) = TRC_4(T_4^*)$ and $T^* = T_4^*$.

E) if $\Delta_{45} \leq 0$, then $TRC(T^*) = TRC_5(T_5^*)$ and $T^* = T_5^*$.

Applying Lemmas 1, 2 and Equations(28a)-(28e), the following results hold.

Theorem 4 Suppose $\frac{PM}{D} \leq \frac{W}{D\rho}$. Hence,

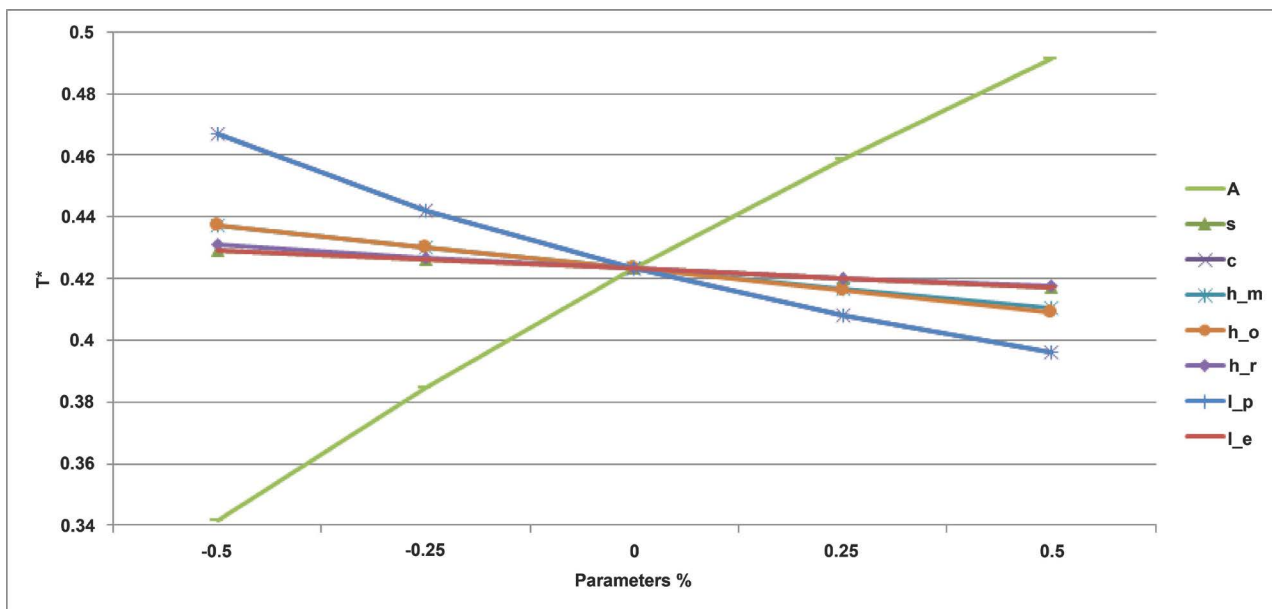

Figure 9. The sensitivity analysis for T^* of this paper.

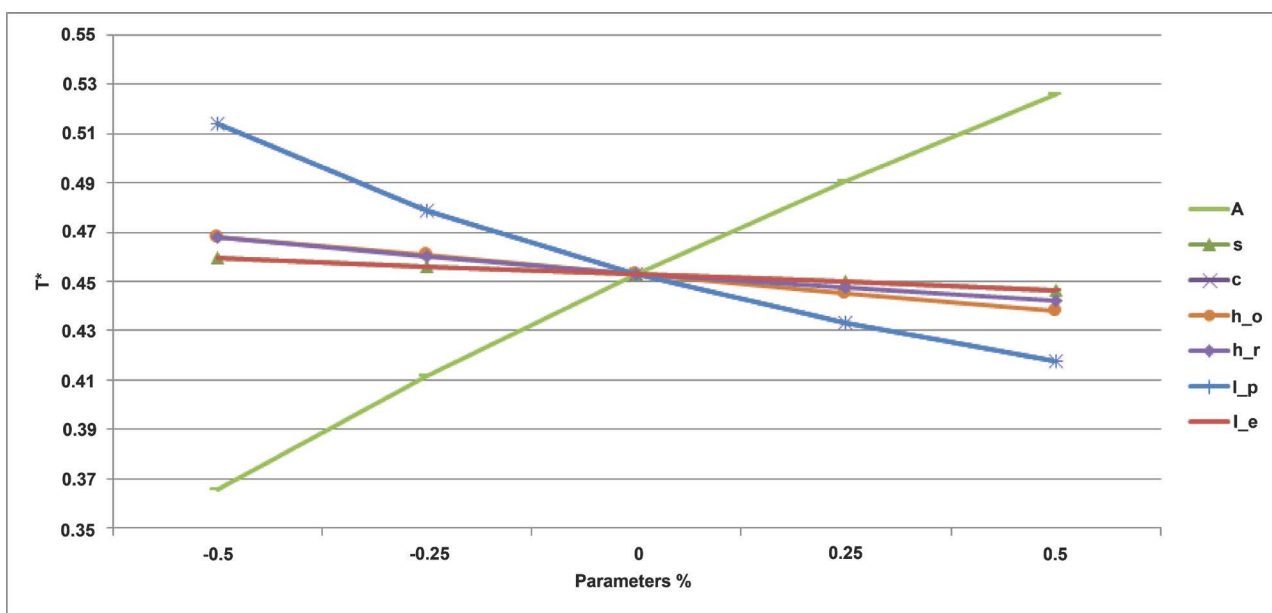

Figure 10. The sensitivity analysis for T^* of [21].

- A) if $0 < \Delta_{16}$, then $TRC(T^*) = TRC_1(T_1^*)$ and $T^* = T_1^*$.
- B) if $\Delta_{16} \leq 0 < \Delta_{67}$, then $TRC(T^*) = TRC_6(T_6^*)$ and $T^* = T_6^*$.
- C) if $\Delta_{67} \leq 0 < \Delta_{78}$, then $TRC(T^*) = TRC_7(T_7^*)$ and $T^* = T_7^*$.
- D) if $\Delta_{78} \leq 0 < \Delta_{85}$, then $TRC(T^*) = TRC_8(T_8^*)$ and $T^* = T_8^*$.
- E) if $\Delta_{85} \leq 0$, then $TRC(T^*) = TRC_5(T_5^*)$ and $T^* = T_5^*$.

7. The Sensitivity Analysis

We execute the sensitivity analysis by Maple 18.00 to find out the unique solution T_i^* when $TRC'_i(T) = 0, i = 1 \sim 8$.

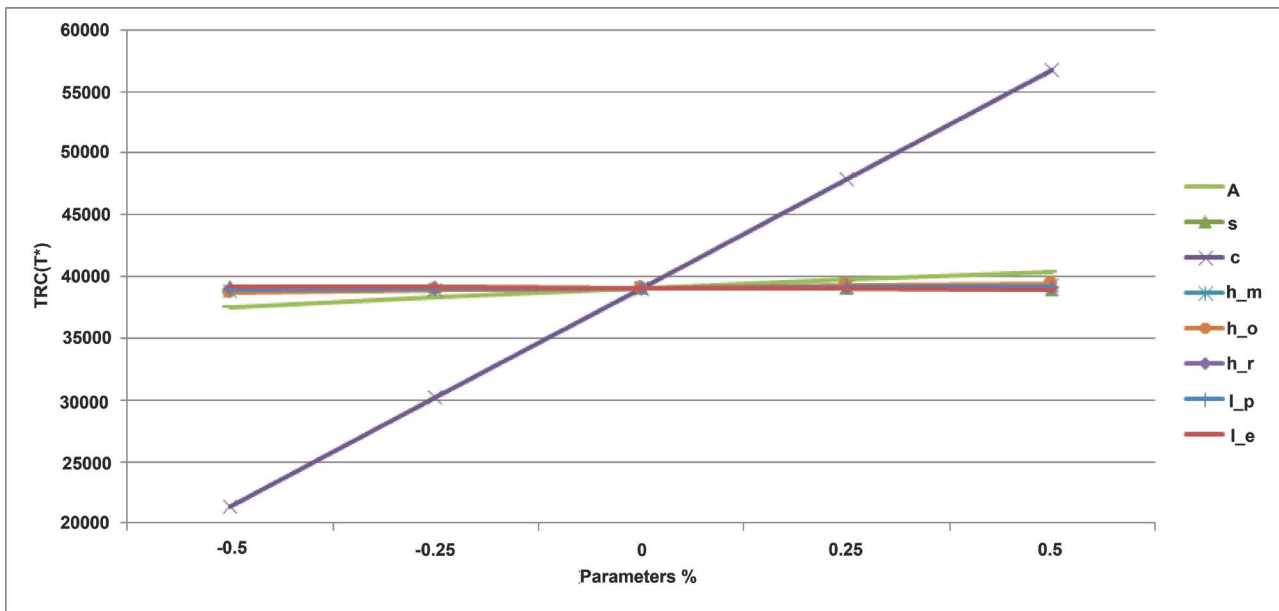

Figure 11. The sensitivity analysis for $TRC(T^*)$ of this paper.

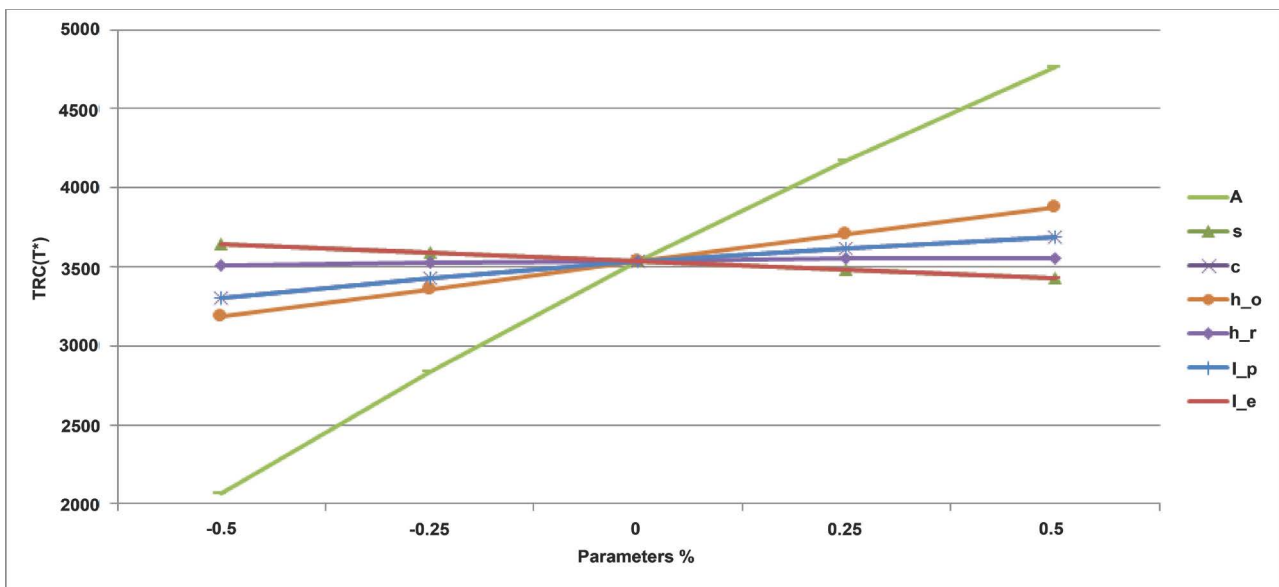

Figure 12. The sensitivity analysis for $TRC(T^*)$ of [21].

Table 1. Comparison of relative parameters impact to T^* and $TRC(T^*)$ in the sensitivity analyses.

2*Impact	T^*, Q^*		$TRC(T)$	
	This paper	[21]	This paper	[21]
Positive & Major	A	A	c	A
Positive & Minor	-	-	A, h _{mp} , h _o , h _p , I _p	c, h _o , h _p , I _p
Negative & Minor	s, h _{mp} , h _o , h _p , I _e	s, h _o , h _p , I _e	s, I _e	s, I _e
Negative & Major	c, I _p	c, I _p	-	-

Given the parameters $P = 5000$ units/year, $D = 3500$ units/year, $A = \$1200/\text{order}$, $s = \$30/\text{unit}$, $c = \$10/\text{unit}$, $h_m = \$1/\text{unit}/\text{year}$, $h_o = \$3/\text{unit}/\text{year}$, $h_r = \$6/\text{unit}/\text{year}$, $I_p = \$0.3/\text{year}$, $I_e = \$0.1/\text{year}$, $M = 100$ days = $100/365$ year, $N = 50$ days = $50/365$ year, $W = 400$ units.

We increase/decrease 25% and 50% of parameters at the same time to execute the sensitivity analysis. Based on the computational results and compare with [21] as shown in **Figures 9-12**, we can get the following results on **Table 1**.

8. Conclusions

EPQ models are being widely used as a decision making tool in practice. Nearly a hundred years, scholars have focused on the production process, but omitted the importance of raw materials during the pre-production process. However, the related costs of raw materials will directly or indirectly affect the annual total relevant cost, thereby generating significant errors so that an overall consideration is needed.

Therefore, this paper presents a new inventory model applies raw materials in [10]'s payment terms, finite replenishment rate and limited storage capacity. Consequently, [21] can be treated as a special case of this paper.

Conflicts of Interest

The authors declare no conflicts of interest regarding the publication of this paper.

References

- [1] Harris, F.W. (1913) How Many Parts to Make at Once. *Factory, the Magazine of Management*, **10**, 135-136.
- [2] Taft, E.W. (1918) The Most Economical Production Lot. *Iron Age*, **101**, 1410-1412.
- [3] Chopra, S. and Meindl, P. (2001) *Supply Chain Management: Strategy, Planning, and Operation*. Pearson Prentice Hall, Upper Saddle River, NJ.
- [4] Lin, S.D. (2010) The Optimal Inventory Policy of Production Management. *Across-Straits Academic Conference Proceedings in Management Theories and Practices*, **213**, 199-202.
- [5] Su, S.M. and Lin, S.D. (2013) The Optimal Inventory Policy of Production Management. *Engineering*, **5**, 9-13. <https://doi.org/10.4236/eng.2013.55A002>
- [6] Su, S.M., Lin, S.D. and Chang, L.F. (2014) The Optimal Inventory Policy for Reusable Items with Random Planning Horizon Considering Present Value. *Applied Mathematics*, **5**, 292-299. <https://doi.org/10.4236/am.2014.52030>
- [7] Goyal, S.K. (1985) Economic Order Quantity under Conditions of Permissible Delay in Payments. *Journal of the Operational Research Society*, **36**, 335-338. <https://doi.org/10.1057/jors.1985.56>
- [8] Huang, Y.F. (2007) Optimal Retailer's Replenishment Decisions in the EPQ Model under Two Levels of Trade Credit Policy. *European Journal of Operational Research*, **176**, 1577-1591. <https://doi.org/10.1016/j.ejor.2005.10.035>
- [9] Huang, Y.F. (2003) Optimal Retailer's Ordering Policies in the EOQ Model under Trade Credit Financing. *Journal of the Operational Research Society*, **54**, 1011-1015.

- <https://doi.org/10.1057/palgrave.jors.2601588>
- [10] Teng, J.T. and Goyal, S.K. (2007) Optimal Ordering Policies for a Retailer in a Supply Chain with Up-Stream and Down-Stream Trade Credits. *Journal of the Operational Research Society*, **58**, 1252-1255. <https://doi.org/10.1057/palgrave.jors.2602404>
- [11] Chung, K.J. (2011) The Simplified Solution Procedures for the Optimal Replenishment Decisions under Two Levels of Trade Credit Policy Depending on the Order Quantity in a Supply Chain System. *Expert Systems with Applications*, **38**, 13482-13486. <https://doi.org/10.1016/j.eswa.2011.04.094>
- [12] Chung, K.J. (2013) The EPQ Model under Conditions of Two Levels of Trade Credit and Limited Storage Capacity in Supply Chain Management. *International Journal of Systems Science*, **44**, 1675-1691. <https://doi.org/10.1080/00207721.2012.669864>
- [13] Huang, Y.F. (2006) An Inventory Model under Two Levels of Trade Credit and Limited Storage Space Derived without Derivatives. *Applied Mathematical Modelling*, **30**, 418-436. <https://doi.org/10.1016/j.apm.2005.05.009>
- [14] Kreng, V.B. and Tan, S.J. (2010) The Optimal Replenishment Decisions under Two Levels of Trade Credit Policy Depending on the Order Quantity. *Expert Systems with Applications*, **37**, 5514-5522. <https://doi.org/10.1016/j.eswa.2009.12.014>
- [15] Min, J., Zhou, Y.W. and Zhao, J. (2010) An Inventory Model for Deteriorating Items under Stock-Dependent Demand and Two-Level Trade Credit. *Applied Mathematical Modelling*, **34**, 3273-3285. <https://doi.org/10.1016/j.apm.2010.02.019>
- [16] Chen, L.H. and Kang, F.S. (2010) Integrated Inventory Models Considering the Two-Level Trade Credit Policy and a Price-Negotiation Scheme. *European Journal of Operational Research*, **205**, 47-58. <https://doi.org/10.1016/j.ejor.2009.11.028>
- [17] Jaggi, C.K., Goyal, S.K. and Goel, S.K. (2008) Retailer's Optimal Replenishment Decisions with Credit-Linked Demand under Permissible Delay in Payments. *European Journal of Operational Research*, **190**, 130-135. <https://doi.org/10.1016/j.ejor.2007.05.042>
- [18] Teng, J.T. (2009) Optimal Ordering Policies for a Retailer Who Offers Distinct Trade Credits to Its Good and Bad Credit Customers. *International Journal of Production Economics*, **119**, 415-423. <https://doi.org/10.1016/j.ijpe.2009.04.004>
- [19] Teng, J.T. and Chang, C.T. (2009) Optimal Manufacturer's Replenishment Policies in the EPQ Model under Two Levels of Trade Credit Policy. *European Journal of Operational Research*, **195**, 358-363. <https://doi.org/10.1016/j.ejor.2008.02.001>
- [20] Yen, G.F., Chung, K.J. and Chen, T.C. (2012) The Optimal Retailer's Ordering Policies with Trade Credit Financing and Limited Storage Capacity in the Supply Chain System. *International Journal of Systems Science*, **43**, 2144-2159.
- [21] Srivastava, H.M., Yen, G.F., Lee, A.K., Wu, Y.X. and Lin, S.D. (2018) The Optimal Retailer's EPQ Policies with Two-Level Trade Credit under Alternate Due Date of Payment and Limited Storage Capacity. *Applied Mathematics & Information Sciences*, **12**, 1073-1089. <https://doi.org/10.18576/amis/120602>
- [22] Hartley, R.V. (1976) *Operations Research: A Managerial Emphasis*. Goodyear Publishing, Pacific Palisades.
- [23] Hariga, M.A. (2011) Inventory Models for Multi-Warehouse Systems under Fixed and Flexible Space Leasing Contracts. *Computers & Industrial Engineering*, **61**, 744-751. <https://doi.org/10.1016/j.cie.2011.05.006>
- [24] Liao, J.J., Chung, K.J. and Huang, K.N. (2013) A Deterministic Inventory Model for

Deteriorating Items with Two Warehouses and Trade Credit in a Supply Chain System. *International Journal of Production Economics*, **146**, 557-565.

- [25] Pakkala, T.P.M. and Achary, K.K. (1992) A Deterministic Inventory Model for Deteriorating Items with Two Warehouses and Finite Replenishment Rate. *European Journal of Operational Research*, **57**, 71-76.
[https://doi.org/10.1016/0377-2217\(92\)90306-T](https://doi.org/10.1016/0377-2217(92)90306-T)
- [26] Thangam, A. and Uthayakumar, R. (2010) Optimal Pricing and Lot-Sizing Policy for a Two-Warehouse Supply Chain System with Perishable Items under Partial Trade Credit Financing. *Operational Research: An International Journal*, **10**, 133-161.
<https://doi.org/10.1007/s12351-009-0066-2>