

Design and Development of Solar-Powered Trolley-Mounted Sprayer

Md. Moudud Ahmmed^{1,2*}, Mohammad Afzal Hossain², Md. Anwar Hossen³, Faria Rahman⁴,
Md Mahabur Hossain⁵

¹Graduate School of Science and Technology, University of Tsukuba, Tsukuba, Japan

²Workshop Machinery and Maintenance Division, Bangladesh Rice Research Institute, Gazipur, Bangladesh

³Farm Machinery and Postharvest Technology Division, Bangladesh Rice Research Institute, Gazipur, Bangladesh

⁴Agricultural Economics Division, Bangladesh Agricultural Research Institute, Gazipur, Bangladesh

⁵Department of Mechanical Engineering, Hajee Mohammad Danesh Science and Technology University, Dinajpur, Bangladesh

Email: *moudud222@gmail.com

How to cite this paper: Ahmmed, M.M., Hossain, M.A., Hossen, M.A., Rahman, F. and Hossain, M.M. (2026) Design and Development of Solar-Powered Trolley-Mounted Sprayer. *Agricultural Sciences*, 17, 430-445.

<https://doi.org/10.4236/as.2026.176026>

Received: April 18, 2026

Accepted: June 8, 2026

Published: June 11, 2026

Copyright © 2026 by author(s) and Scientific Research Publishing Inc. This work is licensed under the Creative Commons Attribution International License (CC BY 4.0).

<http://creativecommons.org/licenses/by/4.0/>



Open Access

Abstract

The increasing demand for sustainable and energy-efficient agricultural practices has encouraged the development of renewable energy-based farm machinery. This study focuses on the design, development, and performance evaluation of a solar-powered trolley-mounted sprayer aimed at improving spraying efficiency while reducing labor dependency and fossil fuel consumption. The developed system consists of a stainless steel (SS) trolley frame, a 20 L liquid storage tank, a 40 W solar photovoltaic panel, a 12 V rechargeable battery (30 Ah), a DC pump, and a five-nozzle spraying unit. The system was designed to ensure uniform spray distribution, enhanced field capacity, and ease of operation under field conditions. Performance evaluation was conducted through laboratory testing at the Workshop Machinery and Maintenance (WMM) Division and field trials at BRRI farm, Gazipur. The results revealed that the trolley-mounted sprayer achieved an average effective field capacity of 0.182 ha/h, which was higher than that of multi-nozzle (0.159 ha/h) and backpack sprayers (0.136 ha/h). Similarly, the average field efficiency of the developed sprayer was recorded as 78.61%, indicating improved operational performance compared to conventional systems. The flow rate of the system ranged between 3.1 and 3.4 L/min, while battery voltage varied from 12.4 V to 13.0 V depending on solar irradiance conditions. The study also analyzed the effect of solar energy variation on system performance, showing that solar irradiance peaked around midday, which correspondingly influenced battery charging, pump speed, and discharge rate. The findings demonstrate that the developed solar-powered trolley-mounted sprayer is an effi-

cient, eco-friendly, and cost-effective solution for agricultural spraying operations, particularly suitable for small and medium-scale farmers.

Keywords

Solar-Powered Sprayer, Farm Mechanization, Eco-Friendly, Energy-Efficient, Solar Irradiance

1. Introduction

Agriculture remains a cornerstone of food security and rural livelihoods, particularly in developing countries where a large proportion of the population depends on crop production for income and sustenance. Among various agronomic practices, plant protection through the application of pesticides, herbicides, and fertilizers is critical for minimizing yield losses caused by pests, diseases, and weeds. However, the effectiveness of these inputs largely depends on the method and efficiency of their application. In many regions, conventional spraying methods such as manually operated knapsack sprayers are still widely used due to their low initial cost and simplicity. Despite their popularity, these systems are associated with several limitations, including high labor requirements, operator fatigue, inconsistent spray distribution, and increased exposure of workers to hazardous chemicals [1] [2].

With the increasing demand for agricultural productivity and the simultaneous decline in available farm labor, there has been a growing interest in mechanized and automated spraying systems. Power-operated and engine-driven sprayers have been introduced to overcome the limitations of manual systems; however, these technologies often rely on fossil fuels, contributing to higher operational costs and environmental pollution [3]. Moreover, the fluctuating prices of fuel and concerns regarding greenhouse gas emissions have intensified the need for alternative, sustainable energy sources in agricultural operations. In this context, renewable energy technologies, particularly solar energy, have emerged as a viable and eco-friendly solution for powering farm machinery [4] [5].

Solar energy is abundant, clean, and increasingly accessible, making it highly suitable for agricultural applications, especially in regions with high solar irradiance. Solar-powered sprayers utilize photovoltaic (PV) panels to convert sunlight into electrical energy, which is stored in batteries and used to operate pumps and spraying mechanisms. Several studies have demonstrated that solar-operated sprayers can significantly reduce labor intensity and eliminate the need for fossil fuels while maintaining satisfactory spraying performance [6] [7]. Additionally, these systems offer advantages such as low operating cost, minimal maintenance, and reduced environmental impact, aligning well with the principles of sustainable and climate-smart agriculture.

Despite these advantages, existing solar-powered sprayers, particularly back-

pack-type systems, often suffer from limitations related to low field capacity, limited tank volume, and restricted spraying width. These constraints reduce their suitability for large-scale operations and limit their overall efficiency [8]. Multi-nozzle sprayers have been developed to increase coverage area and improve efficiency; however, their performance is often influenced by field conditions, operator skill, and system design parameters. Furthermore, the continuous carrying of backpack sprayers imposes significant physical strain on operators, which can negatively affect work performance and health [2].

To address these challenges, the development of trolley-mounted spraying systems has gained attention as an effective alternative. Trolley-mounted sprayers eliminate the need for carrying heavy loads, thereby reducing operator fatigue and improving working conditions. The integration of multiple nozzles with a trolley-based system allows for wider coverage and enhanced spraying uniformity. When combined with solar power, such systems offer a sustainable solution that balances efficiency, cost-effectiveness, and environmental considerations. The use of durable materials such as stainless steel frames further enhances the robustness and longevity of the equipment under field conditions [7].

Another critical factor influencing the performance of solar-powered sprayers is the variability of solar energy throughout the day. Solar irradiance follows a diurnal pattern, typically increasing from morning to midday and decreasing thereafter. This variation directly affects battery charging, pump operation, and flow rate, ultimately influencing spraying performance [4] [5]. Understanding the relationship between solar energy availability and system performance is therefore essential for optimizing the design and operational efficiency of solar-powered agricultural machinery.

In recent years, research efforts have focused on improving the design and functionality of solar sprayers by incorporating advanced components such as efficient DC pumps, optimized nozzle configurations, and improved energy storage systems. Studies have reported that appropriate system design can significantly enhance discharge rate, application uniformity, and field efficiency [3] [6]. However, there remains a need for further development of integrated systems that can achieve higher field capacity while maintaining consistent performance under varying environmental conditions.

In this context, the present study focuses on the design and development of a solar-powered trolley-mounted sprayer aimed at improving operational efficiency and reducing labor dependency in agricultural spraying operations. The developed system incorporates a photovoltaic panel, rechargeable battery, DC pump, and multi-nozzle arrangement mounted on a mobile trolley structure. The performance of the system was evaluated through laboratory testing and field trials to assess its effectiveness under real operating conditions. The experimental results indicated that the trolley-mounted sprayer achieved higher effective field capacity and field efficiency compared to other conventional sprayers, demonstrating its potential for large-scale agricultural applications. Furthermore, the study

examined the influence of solar irradiance on key performance parameters such as battery voltage, current, flow rate, and pump speed, providing valuable insights into system behavior under dynamic environmental conditions.

Overall, the development of solar-powered spraying systems represents a significant step toward sustainable agricultural mechanization. By reducing reliance on fossil fuels and improving operational efficiency, such technologies can contribute to enhanced productivity, reduced environmental impact, and improved farmer welfare. In this study, the specific objectives were to design and develop a solar-powered trolley-mounted sprayer suitable for field conditions, to evaluate its performance in terms of effective field capacity, field efficiency, discharge rate, and application rate, to analyze the influence of solar energy variation on operational parameters such as battery voltage, flow rate, and pump speed, and to compare its performance with other commonly used sprayer types in order to determine its suitability for practical agricultural applications

2. Material and Methods

The study was conducted in two phases to ensure comprehensive evaluation of the developed system. Laboratory testing was carried out at the Workshop Machinery and Maintenance (WMM) Division of the Bangladesh Rice Research Institute (BRRI), Gazipur, Bangladesh, to examine the functional performance and system stability under controlled conditions. Field experiments were subsequently performed at the BRRI research farm, Gazipur, to evaluate the operational performance of the developed sprayer under actual field conditions. A series of repeated trials were conducted to ensure the reliability and consistency of the results. A solar-powered trolley-mounted sprayer was designed and developed to improve spraying efficiency while reducing labor requirements. The system consisted of a structural frame, spraying unit, power unit, and control components. The overall design was prepared using SolidWorks ensuring proper alignment of all components and ease of operation (**Figure 1**).

The sprayer frame was fabricated using stainless steel (SS) to provide durability, corrosion resistance, and structural stability. The system was mounted on a trolley with wheels to facilitate easy movement in the field, thereby eliminating the need for manual carrying. The sprayer included a liquid storage tank with a capacity of 20 liters, mounted securely on the trolley frame. The developed sprayer was powered by a solar photovoltaic (PV) system. A 40 W solar panel (700 mm × 510 mm × 25 mm) was installed on the trolley to capture solar energy. The generated electrical energy was stored in a 12 V rechargeable battery with a capacity of 30 A. The stored energy was used to operate a 12 V DC pump responsible for liquid delivery. The solar panel continuously charged the battery during operation, allowing extended working time. The average charging time of the battery was approximately 6 hours under favorable sunlight conditions. The system was designed to ensure efficient energy utilization and uninterrupted operation during field application.

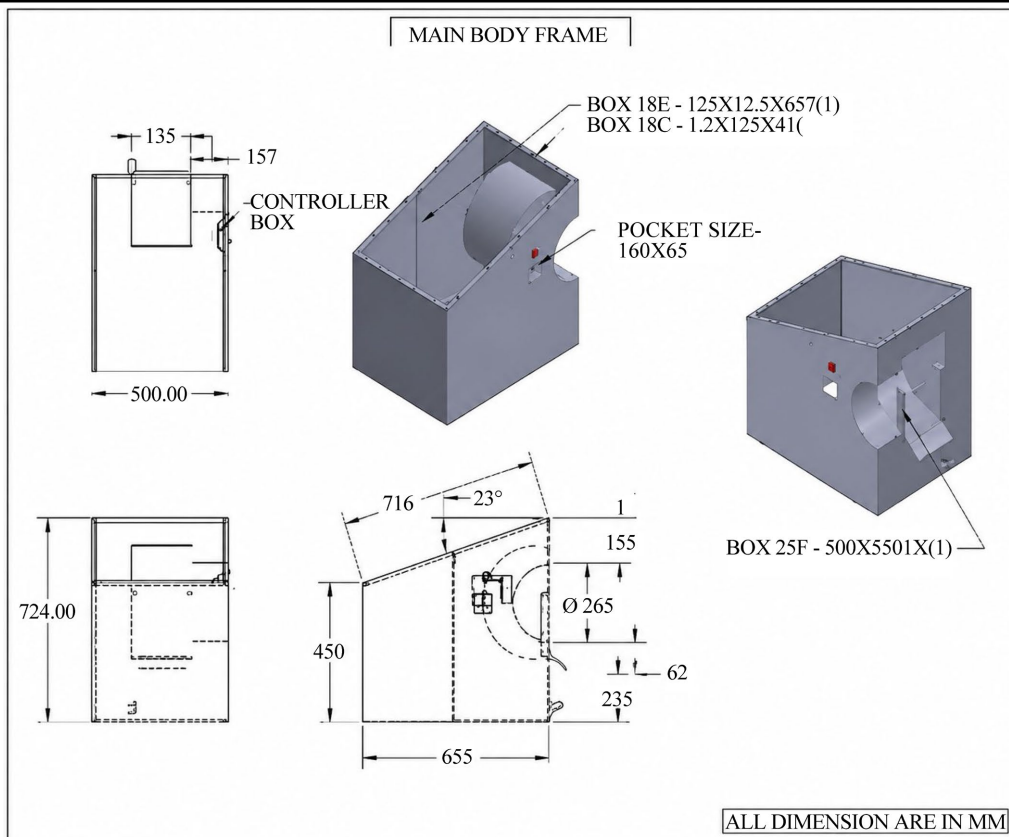
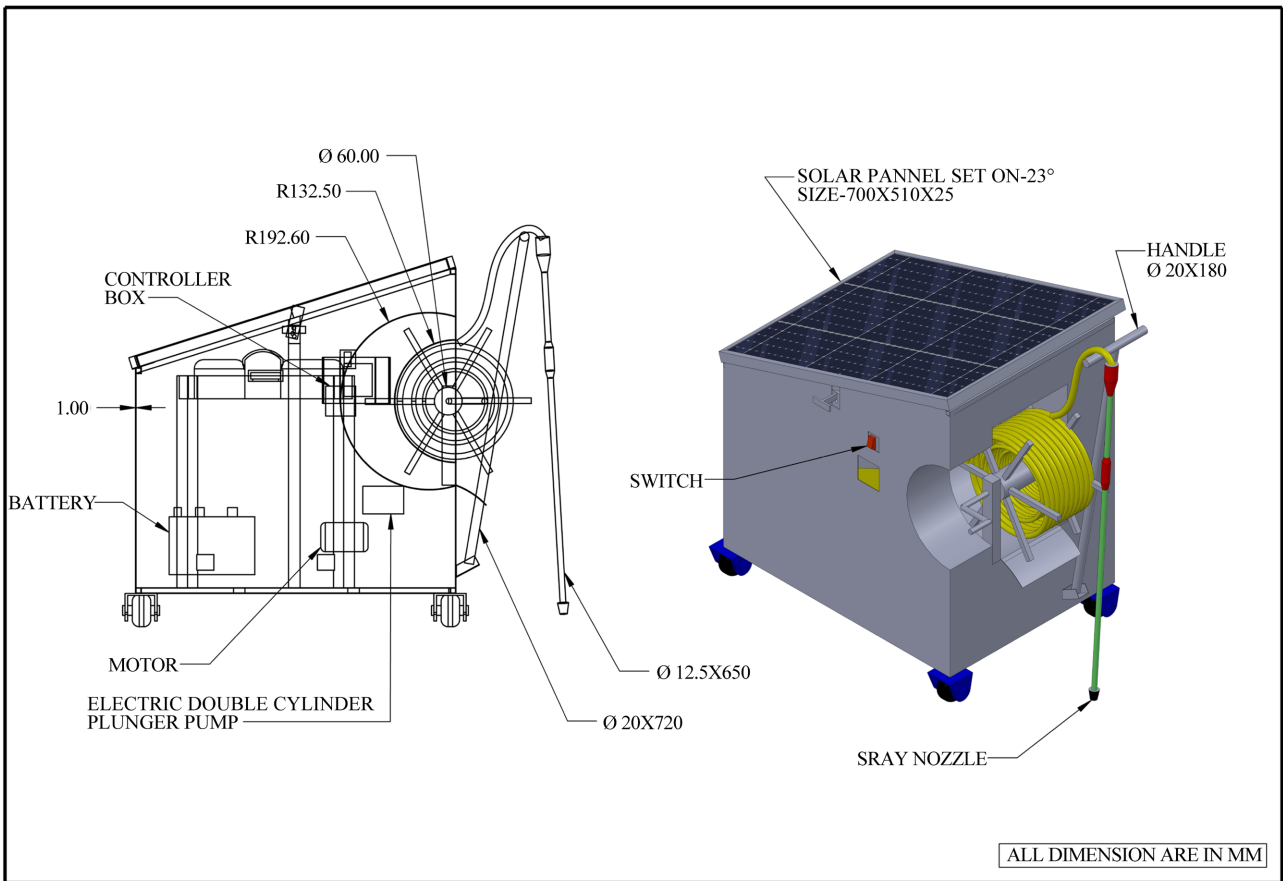

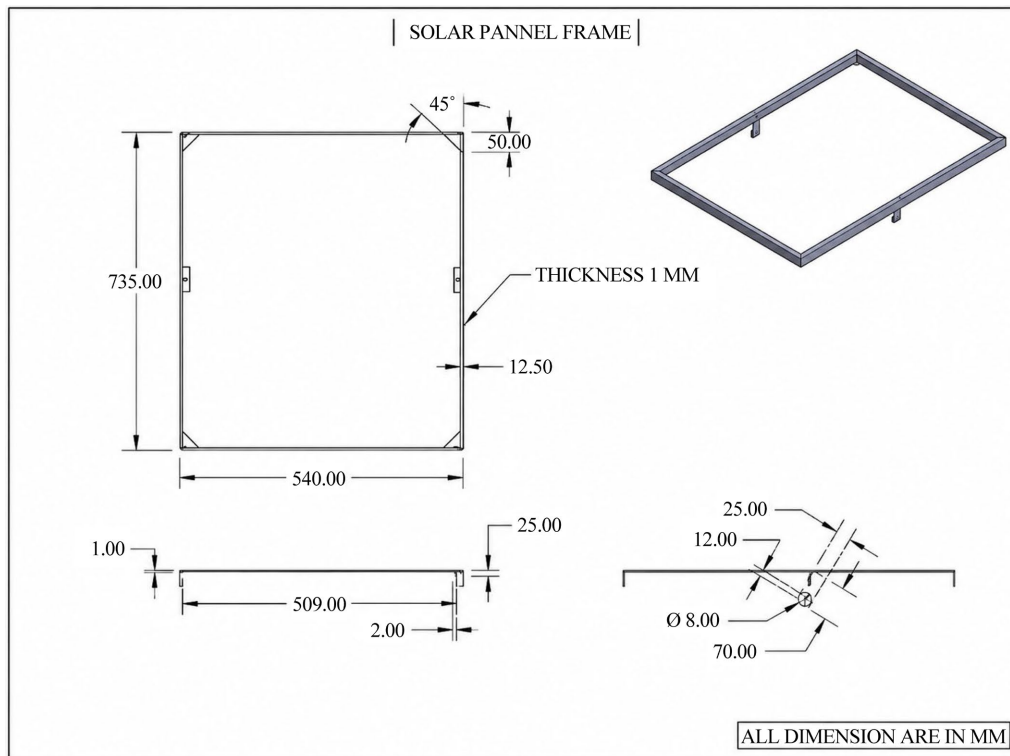

Figure 1. Layout of trolley mounted solar powered sprayer.

2.1. Design Considerations

The solar-powered trolley-mounted sprayer was designed by integrating agronomic requirements, mechanical stability, hydraulic performance, and energy balance to ensure efficient and reliable field operation. The design parameters were selected based on field conditions, crop requirements, and available solar energy.

A primary consideration was the energy requirement and power matching of the system. The photovoltaic panel of 40 W capacity was selected to meet the power demand of the 12 V DC pump and auxiliary electrical components. The system operates with a 12 V battery (30 Ah), which provides a total stored energy of approximately 360 Wh. Considering the pump operates at a maximum current of about 3.0 A, the power consumption is approximately 36 W. Thus, the solar panel capacity was selected to balance energy consumption and charging under typical solar irradiance conditions (200 - 480 W/m² observed during testing). This ensures continuous operation during peak sunlight hours while maintaining battery charge.

The tank capacity and application requirement were also considered. A 20 L tank was selected to balance between operational duration and total system weight. Based on an average flow rate of 3.4 L/min, the tank can provide continuous spraying for approximately 5.8 - 6.0 minutes per full load. This capacity was considered suitable for small plot operations with periodic refilling. The hydraulic design focused on achieving sufficient pressure and uniform discharge. The se-

lected pump operates at a maximum pressure of 0.60 MPa, which is adequate for proper atomization of liquid into fine droplets. The pipe diameter and hose length were selected to minimize frictional losses and maintain steady flow across all nozzles. The discharge rate (Q) of the system is defined as:

$$Q = \frac{V}{T}$$

where V is the collected volume (L) and T is the time (h).

The spraying width and field capacity were optimized to improve efficiency. A spraying width was achieved using a nozzle arrangement. The forward speed was maintained at approximately during operation. Based on these parameters, the theoretical field capacity (TFC) was estimated as:

$$\text{TFC} = \frac{S \times W}{10}$$

where S is speed (km/h) and W is spraying width (m).

This gives a theoretical capacity, which closely matches the experimental results. The effective field capacity observed during field trials was approximately, indicating good system performance. The structural design and weight distribution were also critical. The total weight of the system was approximately 20 kg. To ensure stability, heavy components such as the battery were placed at the lower portion of the frame, while the solar panel was mounted at the top. The trolley dimensions were designed to maintain balance and ease of movement in uneven field conditions.

2.2. Sprayer Components

The solar-powered trolley-mounted sprayer consists of several integrated components that function together to ensure efficient and uniform spraying performance. The system is designed by combining structural, energy, and hydraulic units in a compact and mobile configuration. The major components are described below:

2.2.1. Frame and Trolley Structure

The structural frame of the sprayer is fabricated using stainless steel (SS), providing high strength, durability, and resistance to corrosion under field conditions. The entire system is mounted on a trolley equipped with wheels, which facilitates easy movement across agricultural fields and eliminates the need for manual carrying. The total weight of the system is approximately 20 kg, ensuring both stability and mobility during operation.

2.2.2. Liquid Storage Tank

The sprayer is equipped with a tank having a capacity of 20 liters, centrally positioned on the frame to maintain proper balance. The tank is made of chemical-resistant material to withstand exposure to agrochemicals. It includes a filling inlet with a lid to prevent spillage and an outlet connected to the suction pipe for con-

tinuous liquid flow.

2.2.3. Solar Photovoltaic Panel

A solar panel of 40 W capacity with dimensions of 700 mm × 510 mm × 25 mm is mounted on the top of the trolley. The panel captures solar energy and converts it into electrical energy, which is used to charge the battery and power the system during operation.

2.2.4. Battery and Electrical System

The electrical system consists of a 12 V rechargeable battery with a capacity of 30 Ah, which stores energy generated from the solar panel. During operation, the battery voltage typically ranges between 12.4 V and 13.0 V, and the current varies from 1.6 A to 2.0 A depending on solar irradiance. The system also includes wiring, connectors, and switches for proper power distribution and control.

2.2.5. Pump Unit

A 12 V DC pump is used to deliver liquid from the tank to the spraying system. The pump is capable of generating a maximum pressure of 0.60 MPa and a flow rate of approximately 3.4 L/min. This ensures sufficient pressure for proper atomization and uniform spray application.

2.2.6. Pipeline and Hose System

The hydraulic system includes flexible pipes and hoses that connect the tank, pump, and nozzles. These pipes are designed to minimize pressure losses and prevent leakage. Proper fittings and clamps are used to ensure secure and efficient fluid transfer.

2.2.7. Nozzle Assembly

The sprayer is equipped with five nozzles arranged along a horizontal boom. The nozzles are uniformly spaced to provide a spraying width of approximately 2.0 m. They convert the liquid into fine droplets, ensuring uniform coverage and effective application of agrochemicals.

2.2.8. Control System

The control unit includes switches and basic electrical components that allow the operator to easily start and stop the pump. It ensures safe and controlled operation of the sprayer during field use.

2.2.9. Wheels and Mobility Unit

The trolley is fitted with wheels designed for smooth movement over agricultural land, including uneven terrain. The wheel system reduces operator effort and improves maneuverability during spraying operations.

3. Performance Evaluation

The performance evaluation of the developed solar-powered trolley-mounted sprayer was conducted in two stages: laboratory testing and field evaluation, to

ensure comprehensive assessment under both controlled and real operating conditions (Figure 2). In the first stage, laboratory tests were carried out to examine the functional performance and reliability of individual components as well as the integrated system. The sprayer was operated under controlled conditions to evaluate parameters such as discharge behavior, pump operation, and electrical performance. The proper functioning of the solar panel, battery, DC pump, and nozzle system was verified. The laboratory evaluation also helped to ensure that the system maintained consistent operation and that all components were properly connected and functioning before field deployment.

In the second stage, field evaluation was conducted to assess the operational performance of the sprayer under actual agricultural conditions. The sprayer was operated in a test field to evaluate its effectiveness in terms of area coverage, spraying uniformity, ease of operation, and overall efficiency. Observations were made on the movement of the trolley, stability during operation, and the ability of the system to maintain continuous spraying. The performance of the sprayer was also assessed in relation to environmental conditions, particularly the availability of solar energy during different times of the day. Furthermore, the influence of solar energy on system performance was examined by observing changes in operational behavior throughout the day. The system was found to operate smoothly under varying sunlight conditions, with minor variations in performance that did not significantly affect spraying efficiency. Overall, the performance evaluation demonstrated that the developed solar-powered trolley-mounted sprayer is capable of operating effectively under both laboratory and field conditions, providing reliable and efficient performance suitable for agricultural applications.



Figure 2. Trolley mounted solar powered sprayer.

3.1. Sprayer Parameters

3.1.1. Discharge Rate

The discharge rate of the sprayer was calculated to determine the rate of liquid delivery from the system. It was computed using the following relationship:

$$Q = \frac{V}{T}$$

where,

Q = discharge rate (L/h),
 V = volume of liquid collected (L),
 T = time taken (h).

3.1.2. Application Rate

The application rate indicates the amount of liquid applied per unit area and was calculated as:

$$A_r = \frac{V}{A}$$

where,

A_r = application rate (L/ha),
 V = volume of liquid applied (L),
 A = area covered (ha).

3.1.3. Effective Field Capacity

The effective field capacity represents the actual area covered per unit time during operation and was calculated as:

$$\text{EFC} = \frac{A}{T}$$

where,

EFC = effective field capacity (ha/h),
 A = area covered (ha),
 T = time taken (h).

3.1.4. Theoretical Field Capacity

The theoretical field capacity was determined based on machine parameters as:

$$\text{TFC} = \frac{S \times W}{10}$$

where,

TFC = theoretical field capacity (ha/h),
 S = forward speed (km/h),
 W = spraying width (m).

3.1.5. Field Efficiency

Field efficiency was calculated to assess the performance of the sprayer in real field conditions:

$$\text{Field Efficiency} = \left(\frac{\text{EFC}}{\text{TFC}} \right) \times 100$$

4. Results and Discussion

The performance evaluation of the solar-operated sprayers was conducted in two phases: laboratory testing at the WMM Divisional Workshop and field trials at BRRF Farm, Gazipur. **Table 1** shows that the trolley-mounted sprayer achieved the average effective field capacity (0.182 ha/hr). The effective field capacity of the

trolley-mounted sprayer was evaluated through three observations under field conditions. The results indicate that the sprayer maintained consistent performance across all trials. In the first observation, the sprayer covered an area of 0.0025 ha within 48 seconds, resulting in an effective field capacity of 0.188 ha/h. In the second observation, although the area coverage remained similar, the time taken increased slightly to 50 seconds, leading to a reduced field capacity of 0.180 ha/h. In the third observation, the time taken further increased to 52 seconds, resulting in an effective field capacity of 0.175 ha/h. The variation in effective field capacity across observations can be attributed to minor differences in operating conditions such as movement speed, field surface condition, and operator handling. Despite these variations, the average effective field capacity of the trolley-mounted sprayer was found to be 0.182 ha/h, indicating stable and reliable performance during field operation.

Table 1. Effective Field capacity of different sprayer.

Sprayer Type	Obs. No.	Area Coverage (ha)	Time Taken (sec)	Effective Field Capacity (ha/hr.)	Average Effective Field Capacity (ha/hr.)
Trolley-mounted sprayer	1		48	0.188	
	2	0.0025	50	0.180	0.182
	3		52	0.175	

Table 2 indicates that the trolley-mounted sprayer also had the average field efficiency (78.61%). These results demonstrate that the trolley-mounted sprayer provides greater coverage and efficiency compared to the other types. The field efficiency of the trolley-mounted sprayer was evaluated based on three observations under field conditions, considering parameters such as spraying width, forward speed, theoretical field capacity, and effective field capacity. The spraying width was maintained at 2.00 m and the forward speed at 3.00 km/h for all observations, ensuring consistency in operational conditions. In the first observation, the sprayer achieved a theoretical field capacity of 0.240 ha/h and an effective field capacity of 0.188 ha/h, resulting in a field efficiency of 78.33%. In the second observation, the theoretical field capacity slightly decreased to 0.232 ha/h, while the effective field capacity was recorded at 0.180 ha/h, giving a field efficiency of 77.50%. In the third observation, the theoretical field capacity further reduced to 0.219 ha/h, with an effective field capacity of 0.175 ha/h, resulting in a slightly higher field efficiency of 80.00%. The variation in theoretical and effective field capacities across the observations may be attributed to minor changes in field conditions, operator handling, and movement consistency. Despite these variations, the average field efficiency of the trolley-mounted sprayer was found to be 78.61%, indicating good operational performance and effective utilization of the machine under field conditions.

Table 2. Field efficiency of different sprayer.

Sprayer Type	Obs. No.	Spraying Width (m)	Forward Speed (km/hr)	Theoretical Field Capacity (ha/hr)	Effective Field Capacity (ha/hr)	Field Efficiency (%)	Average Field Efficiency (%)
Trolley-mounted sprayer	1	2.00	3.00	0.240	0.188	78.33	78.61
	2	2.00	3.00	0.232	0.180	77.50	
	3	2.00	3.00	0.219	0.175	80.00	

Battery voltage increases with daytime as solar charging progresses, while current follows a similar trend (Figure 3). Solar irradiance peaks midday and decreases thereafter, causing a corresponding drop in flow rate (Figure 4). Trolley Mounted Sprayer: Battery voltage increases with time as solar irradiance rises, while the flow rate slightly decreases during peak hours (Figure 3). Solar irradiance shows a typical diurnal pattern, peaking around midday and gradually declining toward evening (Figure 4).

**Figure 3.** Variation of battery voltage and current with daytime in trolley mounted sprayer.**Figure 4.** Variation of solar irradiance and flow rate with daytime in trolley mounted sprayer.

Figure 3 illustrates the variation of battery voltage and current with respect to daytime in the trolley-mounted sprayer. It is observed that both battery voltage and current follow a similar increasing trend from morning to midday, corresponding to the rise in solar energy availability. During the early hours of the day, the battery voltage and current remain relatively low due to limited solar irradiance. As the intensity of sunlight increases toward midday, the photovoltaic panel generates more power, resulting in an increase in battery charging rate, voltage level, and current flow. After reaching peak values around midday, both voltage and current gradually decrease toward the evening as solar irradiance declines. This trend indicates that the electrical performance of the system is directly influenced by solar energy availability and follows a typical diurnal pattern. **Figure 4** presents the variation of solar irradiance and flow rate with daytime. The solar irradiance increases steadily from morning, reaches its maximum during midday, and then decreases gradually toward the evening. The flow rate of the sprayer shows a similar pattern, although the variation is relatively moderate compared to solar irradiance. As solar irradiance increases, the energy supplied to the pump also increases, resulting in a slight improvement in flow rate. Conversely, when solar irradiance decreases, the flow rate shows a minor reduction. However, the flow rate remains relatively stable throughout the day, indicating that the system is capable of maintaining consistent spraying performance despite fluctuations in solar energy.

Table 3. Detailed technical specifications of solar-operated sprayers.

Items	Trolley mounted solar powered sprayer
Type of sprayer	Solar-operated, Trolley mounted (SS frame)
Capacity of the tank	20 L
Solar panel power	40 W
Solar panel size	700 mm × 510 × 25 mm
Battery current	30 A
Pump voltage	12 V (DC)
Charging time (hr)	6
Number of nozzle (nos.)	5
Max Pressure (MPa)	0.60
Open Flow (L/min)	3.4
Battery Voltage (VDC)	12
Max Current (A)	3.0
Net weight	20 kg

Table 3 presents the detailed technical specifications of the developed trolley-mounted solar-operated sprayer. The sprayer was designed with a stainless-steel (SS) trolley-mounted frame to enhance durability and field mobility. It was

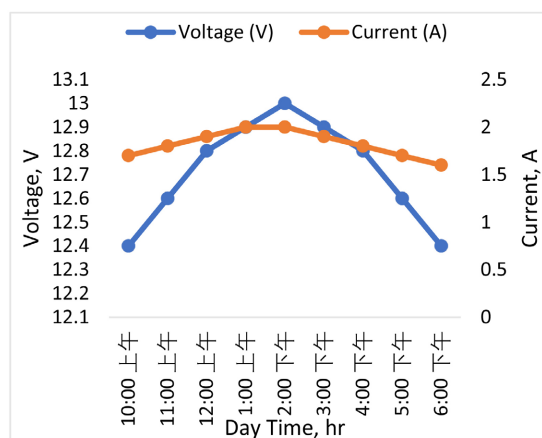
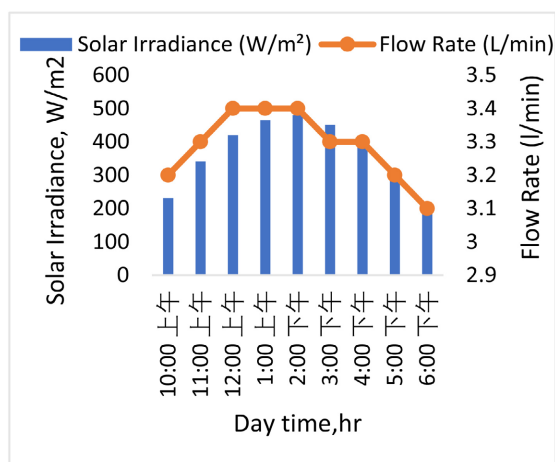
equipped with a 20 L chemical tank and powered by a 40 W solar panel measuring 700 mm × 510 mm × 25 mm. A 12 V DC pump connected to a 12 V, 30 A battery supplied the required operating pressure and discharge for spraying operations. The system required approximately 6 hours for full battery charging. The sprayer incorporated five nozzles to increase spraying width and improve field efficiency. The maximum operating pressure and open flow rate were 0.60 MPa and 3.4 L min⁻¹, respectively, while the maximum current consumption was 3.0 A. The total net weight of the machine was 20 kg, making it suitable for practical field applications and easy maneuverability.

5. Recommendations

- ❖ Increase solar panel capacity or add auxiliary panels to ensure sufficient power supply during low irradiance conditions.
- ❖ Use a higher-capacity battery or advanced energy storage system to extend operational time and improve reliability.
- ❖ Reduce overall system weight by adopting lightweight materials such as aluminum or composite structures for better mobility.
- ❖ Optimize nozzle type, spacing, and orientation to enhance spray uniformity and minimize chemical wastage.
- ❖ Incorporate pressure regulators and flow control valves to maintain consistent discharge under varying field conditions.
- ❖ Improve wheel design and trolley ergonomics to facilitate easier movement in uneven and muddy fields.
- ❖ Integrate smart technologies such as sensors, IoT modules, and real-time monitoring systems for precision spraying.
- ❖ Consider adding GPS or semi-autonomous navigation systems to reduce operator effort and improve field coverage accuracy.
- ❖ Conduct long-term field testing under different crops and environmental conditions to validate durability and adaptability.
- ❖ Provide training programs and technical guidance to farmers for effective use and maintenance of the system.
- ❖ Promote financial support or subsidy programs to encourage adoption of solar-powered sprayers among small and medium-scale farmers.

6. Conclusion

The present study successfully designed, developed, and evaluated a solar-powered trolley-mounted sprayer aimed at improving spraying efficiency while reducing labor requirement and dependency on fossil fuels. The integration of a photovoltaic panel, rechargeable battery, DC pump, and multi-nozzle system within a mobile trolley structure provided a practical and sustainable solution for agricultural spraying operations. The performance evaluation demonstrated that the developed sprayer achieved a higher effective field capacity of 0.182 ha/h and field efficiency of 78.61% compared to conventional backpack and multi-nozzle spray-

ers. The system also maintained a consistent flow rate ranging from 3.1 to 3.4 L/min, indicating stable hydraulic performance. The analysis of solar energy influence revealed that system performance is closely related to solar irradiance, which follows a diurnal pattern with peak values at midday. Correspondingly, battery voltage and pump speed increased during peak solar hours, enhancing spraying performance, while slight reductions were observed during lower irradiance periods. Despite minor fluctuations, the system maintained satisfactory operation throughout the day. The trolley-mounted configuration significantly reduced operator fatigue and improved ease of operation, making it more suitable for extended field use. Overall, the developed solar-powered trolley-mounted sprayer proved to be an efficient, environmentally friendly, and cost-effective alternative to conventional spraying systems. It has strong potential for adoption in small and medium-scale farming, contributing to sustainable agricultural mechanization and improved productivity.

Acknowledgements

The authors gratefully acknowledge the LSTD Project, BRRI, for funding this research work.

Statement of Informed Consent

Informed consent was obtained from all individual participants included in the study.

Conflicts of Interest

The authors declare no conflict of interest in this work. The authors declare that they have no known competing financial interests or personal relationships that could have appeared to influence the work reported in this paper.

References

- [1] Hossain, M.A., Rahman, M.M. and Islam, M.T. (2015) Development and Performance Evaluation of a Manually Operated Knapsack Sprayer. *Journal of Agricultural Engineering*, **52**, 45-52.
- [2] Matthews, G.A. (2016) Pesticide Application Methods. 4th Edition, Wiley-Blackwell.
- [3] Singh, S., Kumar, V. and Singh, R. (2019) Design and Development of a Multi-Nozzle Agricultural Sprayer for Enhanced Field Efficiency. *Journal of Farm Machinery and Power Engineering*, **26**, 78-85.
- [4] Acosta-Silva, Y.J., Torres-Pacheco, I., Matsumoto, Y., Toledano-Ayala, M., Soto-Zarazúa, G.M., Zelaya-Ángel, O. and Méndez-López, A. (2019) Applications of Solar and Wind Renewable Energy in Agriculture: A Review. *Science Progress*, **102**, 127-140. <https://doi.org/10.1177/0036850419832696>
- [5] Sharma, R. and Goel, S. (2017) Performance Analysis of a 11.2 kWp Roof Top Grid-Connected PV System in Eastern India. *Energy Reports*, **3**, 76-84. <https://doi.org/10.1016/j.egy.2017.05.001>
- [6] Islam, M., Nasrin, M.T., Rahman, M.M. and Islam, M.M. (2023) Fabrication and Per-

formance Evaluation of a Solar-Operated Pesticide Sprayer. *Agricultural Engineering International: CIGR Journal*, **26**, 83-92.

- [7] Mishra, A., Bhagat, N. and Singh, P. (2019) Development of Solar Operated Sprayer for Small Scale Farmers. *International Journal of Current Microbiology and Applied Sciences*, **8**, 2593-2596. <https://doi.org/10.20546/ijcmas.2019.802.301>
- [8] Rahman, M.M., Hossain, M.A. and Islam, M.S. (2018) Comparative Performance Evaluation of Different Types of Sprayers Used in Bangladesh Agriculture. *Bangladesh Journal of Agricultural Research*, **43**, 235-245.